

# JOURNAL

EPRI

ELECTRIC POWER RESEARCH INSTITUTE

## Sharing Knowledge in the Digital Age



ALSO IN THIS ISSUE:

- New Fish Protection Regulation
- Next-Generation Heat Pump
- Key Safety Innovations in Electric Power

The Electric Power Research Institute, Inc. (EPRI, [www.epri.com](http://www.epri.com)) conducts research and development relating to the generation, delivery and use of electricity for the benefit of the public. An independent, nonprofit organization, EPRI brings together its scientists and engineers as well as experts from academia and industry to help address challenges in electricity, including reliability, efficiency, affordability, health, safety and the environment. EPRI also provides technology, policy and economic analyses to drive long-range research and development planning, and supports research in emerging technologies. EPRI's members represent approximately 90 percent of the electricity generated and delivered in the United States, and international participation extends to more than 30 countries. EPRI's principal offices and laboratories are located in Palo Alto, Calif.; Charlotte, N.C.; Knoxville, Tenn.; and Lenox, Mass.

Together... Shaping the Future of Electricity®

#### **EPRI Journal Staff and Contributors**

Hank Courtright, *Publisher/Senior Vice President, Global Strategy and External Relations*

Jeremy Dreier, *Editor-in-Chief/Senior Communications Manager*

Michael Matz, *Managing Editor*

Jeannine Howatt, *Business Manager*

Mike Szwed, *Senior Graphic Designer*

#### **Contact Information**

Editor-in-Chief

EPRI Journal

1300 West W. T. Harris Blvd.

Charlotte, North Carolina 28262

For information on subscriptions and permissions, call the EPRI Customer Assistance Center at 800.313.3774 and press 4, or e-mail [journal@epri.com](mailto:journal@epri.com). Please include the code number from your mailing label with inquiries about your subscription.

Current and recent editions of the *EPRI Journal* may be viewed online at [www.epri.com/Pages/Newsroom.aspx](http://www.epri.com/Pages/Newsroom.aspx).

Visit EPRI's web site at [www.epri.com](http://www.epri.com).

# JOURNAL

SPRING 2015

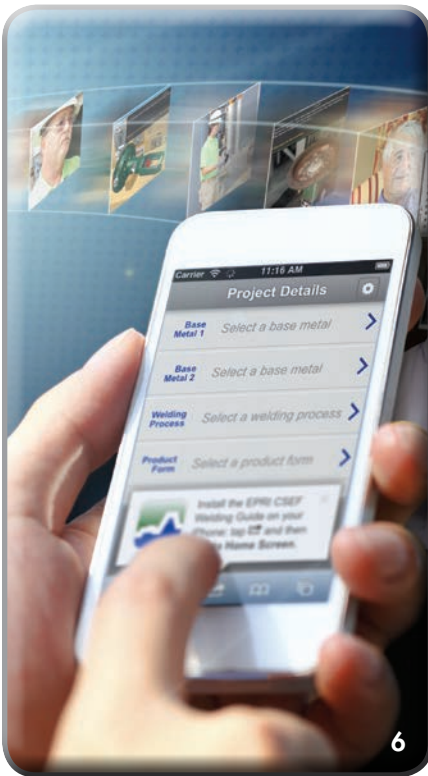

6

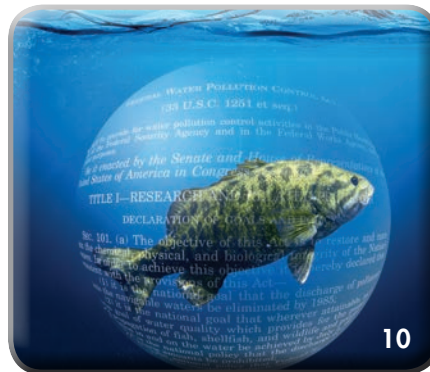

10



20



14

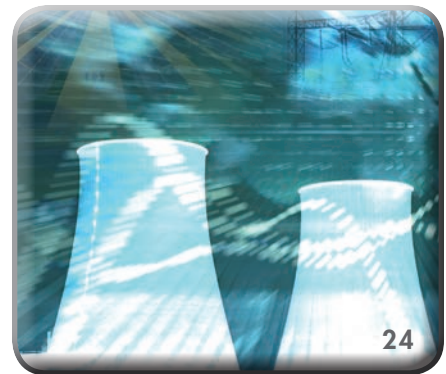

24

## VIEWPOINT

### 2 Going Digital: Better Tools, Better Products, and a Legacy of Learning

## FEATURES

### 6 Sharing Knowledge in the Digital Age

EPRI increasingly uses videos, apps, and other digital materials to report, instruct, educate, and equip those who rely on and use EPRI's work.

### 10 Navigating Tricky Waters

A decade of EPRI R&D on fish protection helps power plant owners and operators navigate new EPA regulations on cooling water intakes.

### 14 Next-Generation Heat Pump

With enhanced efficiency and grid interactivity, EPRI's next-generation heat pump could dramatically increase its adoption among utilities and consumers.

### 20 Cultivating a Culture of Safety

*EPRI Journal* reviews nine key safety innovations in the electric power industry over the past century.

### 24 The Path to Global Energy Security: A Nuclear Perspective

Retired Progress Energy Chief Nuclear Officer Jim Scarola discusses the importance of advancing the right behaviors, standards, and technologies to support global energy security and public safety.

## DEPARTMENTS

### 4 Shaping the Future

### 18 R&D Quick Hits

### 28 Innovation

### 30 In Development

### 32 In the Field

### 34 Technology at Work

### 36 Reports and Software

### 37 Wired In



## Going Digital: Better Tools, Better Products, and a Legacy of Learning

### **EPRI Journal Goes Digital**

With this issue, *EPRI Journal* joins a comprehensive, long-term effort throughout EPRI to use digital media to work and communicate more effectively with our members, our stakeholders, and the public. This is the final edition we will print and mail directly to our subscribers. Later this year, the *Journal* will be produced online and delivered to subscribers through computers and mobile devices. Subscribers will receive email notifications when we update *Journal* content, which we will do six times a year rather than the current three times a year.

This gives us opportunities to provide readers with more timely information and insights, and to deliver it through diverse and interactive media. *EPRI Journal* will complement our other web-based news and information. We will use social media to make it more broadly accessible and useful. Our goal is to engage more fully with readers and to make *EPRI Journal* more readily available to more people. We will provide updates and information on the change, encouraging *EPRI Journal* readers to provide us with ideas and suggestions.

**EPRI**  
**JOURNAL**

### **Digital Becomes Fundamental**

This change for *EPRI Journal* is integral to a much broader thinking and action across EPRI. At its most basic, EPRI produces and delivers actionable information. We accomplish this through meetings and collaborative forums and through reports, software, and other means, including *EPRI Journal*. Along with the news media, education, and business, our traditional models of providing and sharing information are being turned upside down and inside out by digital technology and media.

This is driving us to create a vision of our future digital business interactions with our members, employees, vendors, equipment providers, and other stakeholders. We recognize that the total experience for people interacting with and depending on



EPRI will, to a significant extent, be a digital experience. This *Journal's* cover story provides good insights into how we are working to harness digital technology for sharing knowledge—which is fundamental to everything we do.

Our broad digital strategy, along with information technology and its many facets, is much more than just “IT” or “e-business” as we have thought of them traditionally. Across EPRI we are looking at fundamental processes, transactions, and relationships, so that we don’t just bolt on software, but rather make digital tools and media integral to our work. Having said that, we are prioritizing familiar tools and processes, including:

- Search engine – a flexible, robust capability for members and others to quickly access years of research results
- Technology transfer processes and tools – the ability to use research results will provide significant payoff for our members and society
- Better virtual capabilities for meetings and conferences
- New processes, platforms, and tools for collaboration both inside EPRI and with its collaborators worldwide.

People throughout EPRI have been recruited to drive an initiative we call Research Reimagined & Delivered that is actively seeking innovative ways for us to conduct and deliver our work. I see enthusiastic support across our organization, and a willingness to take a fresh look at all we do and to really push for breakthroughs and innovations.



Research Reimagined & Delivered

### Linking Digital Education to R&D

Another initiative at EPRI has generated interest and enthusiasm because it gives us an opportunity to provide a real legacy of learning for the next generation of power systems engineers—and digital technology will be a key. GridEd is a collaborative educational initiative of EPRI, Georgia Institute of Technology, University of North Carolina at Charlotte, Clarkson University, University of Puerto Rico Mayaguez, and utility and industry sponsors. In 2013, the U.S. Department of Energy awarded EPRI and its team a project known as Grid Engineering for Accelerated Renewable Energy Deployment (GEARED).

As part of GEARED, GridEd seeks to develop and train the next generation of power engineers to anticipate and address the changing requirements of the power system.

Through this effort, we will tap electric industry research, expertise from career utility engineers, EPRI experts, academia, and others to educate the grid’s future workforce. We’re looking at knowledge gaps and existing curricula and courses to determine how we can augment these with resources for both academic and professional education. We’re exploring direct outreach, short courses, and e-learning modules, and in the digital world I can foresee professionals and students drawing on these resources for many years to come and from anywhere in the world.



The Center for Grid Engineering Education

### “Gee Whiz” but Down to Earth

Those of us who have witnessed the digital revolution can still appreciate the “gee whiz” aspects. Everyone can appreciate the significant gains in productivity and effectiveness in our everyday work. For me this is the most gratifying aspect of these initiatives. We can deliver a magazine to more people more quickly and with more diverse, interactive content. We can fundamentally re-tool our R&D to make it more useful and user-focused. And we can provide future generations with a legacy of scientific research and accumulated wisdom that they can put to good use for decades to come.

**Michael W. Howard**  
*President and Chief Executive Officer*

# SHAPING THE FUTURE

*Innovative approaches to upcoming challenges*



## **EPRI Studies Carbon Capture at Combined-Cycle Plant in Spain**

Although a natural-gas–combined-cycle plant emits about half the carbon dioxide of a conventional coal plant, a massive transition from coal- to gas-powered plants is not enough to adequately address the carbon reductions being contemplated domestically and internationally. “Just switching everything to natural gas won’t get you the carbon reduction levels needed to meet the targets,” said EPRI’s Des Dillon.

Which is why Dillon and Dale Grace, both EPRI senior technical leaders, spearheaded a study on the performance and cost impacts of retrofitting Spanish utility Gas Natural Fenosa’s 1200-megawatt combined-cycle plant in Cartagena with carbon capture technology.

In most scenarios worldwide, carbon capture and storage (CCS) is uneconomical at natural gas and coal fired plants; installation of carbon capture equipment is unlikely near-term. A handful of small (10 to 25 megawatts) CCS demonstration projects worldwide has been followed by the 110-megawatt Boundary Dam coal plant in Canada, which opened last October as the first large-scale power generation facility built and operated with CCS. Its economics benefit from government support, Canada’s carbon legislation, and the sale of captured CO<sub>2</sub> to nearby oil fields for enhanced oil recovery.

### **Site-Specific Guidance and Industry Cost Targets**

The Cartagena analysis modeled a retrofit with commercially available technology based on the plant’s current equipment and site, providing the utility with guidance on performance and cost.

“This work helps the utility make a compelling argument to regulators and the public that doing carbon capture now is difficult because of the economics,” said Dillon. “If the economics change, the utility is better positioned for a credible analysis of carbon capture retrofit.”

The study reveals the importance of evaluating the technology in the context of a plant’s specific layout, equipment, and market conditions. For example, natural gas is three to four times more expensive in Spain than in the United States. The Cartagena plant has a low *capacity factor*—meaning that it runs at low output levels—because of the country’s struggling economy and the addition of significant renewable energy over the past decade.

While these factors make a retrofit uneconomical now for Cartagena, the EPRI study outlines circumstances when it would make financial sense. The best-case scenario: running the plant at a capacity factor above 70% and retrofitting all three generation units for economies of scale.

Other takeaways include how to minimize the retrofit’s impact on plant efficiency and net power output, as well as impacts on site water use. The study provides cost and performance targets that carbon capture developers with new technology need to surpass.

But a bigger lesson may simply be the importance of being prepared for a future that includes more gas and significantly reduced carbon emissions. “These issues are not going away,” said Grace.

*For more information, contact Dale Grace at [dgrace@epri.com](mailto:dgrace@epri.com), 650.855.2043, or Des Dillon at [ddillon@epri.com](mailto:ddillon@epri.com), 650.855.2036.*

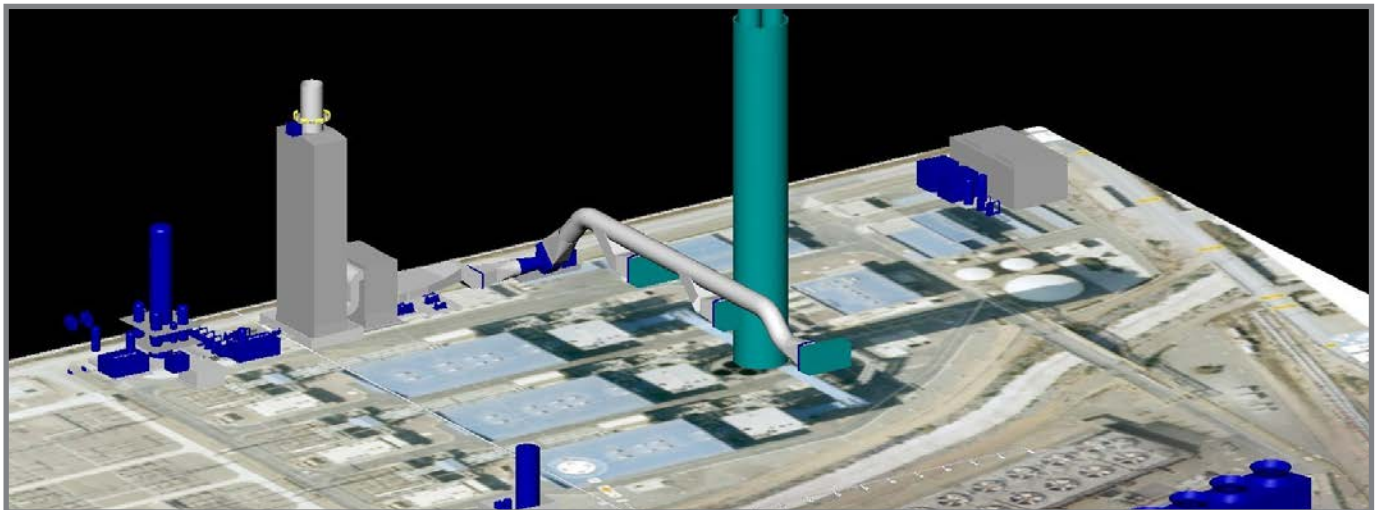

*One of several proposed layouts for full-scale carbon capture retrofit at the Cartagena natural-gas–combined-cycle plant.*



## EPRI Informs Stakeholders and Public with Clean Power Plan Comments

Nobody at EPRI had to pull an all-nighter to meet the U.S. Environmental Protection Agency’s (EPA) deadline for comments on the Obama administration’s proposal to reduce carbon emissions from existing power plants. Indeed, EPRI submitted its input on the Clean Power Plan a full six weeks before the December 1, 2014 deadline.

Weighing in promptly was no accident. “Given EPRI’s public-informing role, we provided our comments early so that our members, government agencies, public utilities commissions, and the general public would be able to take value from our research,” said Francisco de la Chesnaye, technical executive in EPRI’s Energy and Environmental Analysis Group.

While EPRI routinely contributes fact-based comments on pending regulations—recent examples include Clean Water Act rules and EPA’s pending ozone standards—the need was especially acute with the much-discussed Clean Power Plan. Unveiled in June last year, the proposed rule aims to cut the carbon dioxide emissions from existing generation units by 30% from 2005 levels and charges states to devise their own roadmaps to the target. When the regulations are finalized, likely this summer, states have three years to complete those plans—with compliance expected to begin in 2020.

### Observations on Compliance Flexibility and Reliability

In its comments, EPRI sought to alert EPA and other stakeholders to information critical for consideration before the rule is finalized. The wide-ranging comments were based on existing EPRI research.

One key comment: While the proposed rule provides multiple avenues for compliance, some of its basic assumptions do not reflect the significant differences among states and their electric system infrastructures. “If you are developing emission mitigation targets, they should take into account state-specific realities,” said de la Chesnaye. By not recognizing the U.S. power system’s heterogeneity, the EPA rules could establish an inflexible compliance regime.

EPRI also recommended a re-assessment of the impact on power reliability. To meet its goals, the EPA proposes that natural-gas-combined-cycle power plants, which emit less greenhouse gases than coal plants, supply more baseload power. At the same time, the EPA estimates a dramatic increase in generation from variable sources such as solar and wind. In its comments, EPRI points out that there is little long-term experience with natural gas plants operating more or less continuously and calls for more detailed evaluation to ensure that power system reliability doesn’t suffer.

## Clean Power Plan: Key Milestones

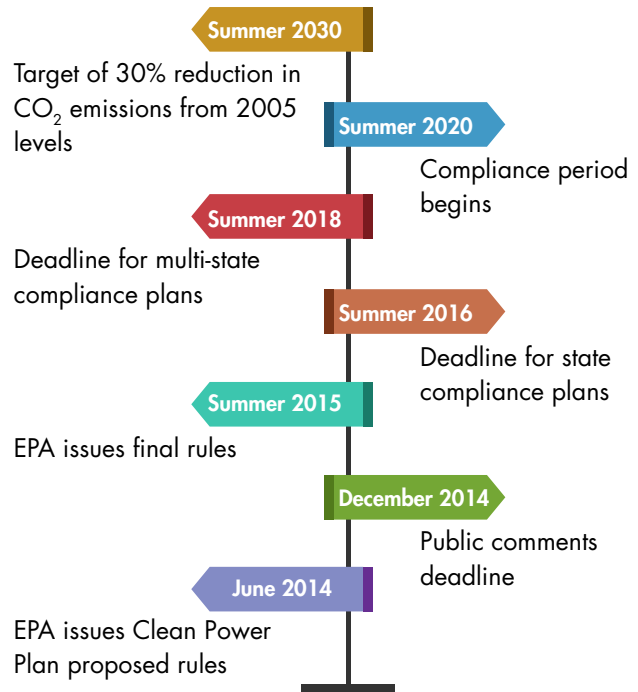

At least a dozen public utility commissions and state governments rolled EPRI’s comments into their own, and a recent hearing at the Federal Energy Regulatory Commission included discussion of EPRI’s findings. “This is one way we uphold our public interest mission,” said de la Chesnaye.

### Helping States with Compliance

What is EPRI’s role as the Clean Power Plan moves toward compliance? Given the emphasis on state-driven compliance plans, de la Chesnaye sees future EPRI research and analysis focusing at the state level. EPRI recently modified its U.S. Regional Economy, Greenhouse Gas, and Energy (US-REGEN) Model so that it can evaluate state-level implications of the Clean Power Plan. “Such analyses will help EPRI members and the states as they look toward reducing emissions,” he said.

EPRI staff in other research sectors will contribute expertise and analysis for a better understanding of emission reduction opportunities and reliability questions. The goal of all of this work is the same. “As the Clean Power Plan develops and other greenhouse gas regulations are put forward, our research will continue to provide value to our members and objectively inform the public policy discourse,” said de la Chesnaye.

*For more information, contact Francisco de la Chesnaye, [fdelachesnaye@epri.com](mailto:fdelachesnaye@epri.com), 202.293.6347.*

# Sharing Knowledge in the Digital Age: EPRI Produces Apps and Videos for All Generations





**W**hen Jim Heishman started his first power plant job decades ago, he had a simple formula for finding answers to his questions. “I went to the library and read books,” said Heishman, senior program manager in EPRI’s Nuclear Maintenance Applications Center.

About a year and a half ago, Heishman learned a powerful lesson about how today’s young professionals seek knowledge. At a conference in Canada, he gave a presentation to 60 engineers about EPRI’s new app to guide work on air-operated valves (AOV), a common component in nuclear plant feedwater systems. Just moments after showing a slide with the EPRI product numbers for the app’s PC and Android versions, Heishman was interrupted. “There was a young engineer who pulled out his Android phone and downloaded it while I was talking,” he recalled. “Before I could get to the next slide, he held it up and said, ‘This is really cool.’”

That experience reinforced Heishman’s conviction that EPRI must continue to transform its tools and methods for sharing

## THE STORY IN BRIEF

Gone are the days when 500-page reports served as the only means of sharing EPRI research results and technical knowledge. For both young and seasoned professionals, EPRI increasingly uses videos, apps, and other digital materials to report, instruct, educate, and equip those who rely on and use EPRI’s work.

vital industry knowledge in ways that younger professionals will embrace. Diversifying EPRI’s products to include videos, apps, and other interactive tools is especially pressing right now. “A lot of the folks who have worked in the power plants for the last 30 years are leaving, and the newer generation likes to learn with their iPhones and smart devices,” said Heishman.

Since 2012, Heishman has led an initiative in EPRI’s Nuclear R&D sector to develop more effective, relevant knowledge transfer—an objective also being pursued by EPRI’s other research sectors. These efforts reflect both the younger generation’s

preferred mode of learning and the retirement wave among the older generation. “Time—or, to be more precise, lack of it—is a genuine issue,” said Neva Espinoza, a senior program manager leading Generation sector research to improve power plant operations. “A lot of new employees are trying to get up to speed very quickly.”

Espinoza helped develop a series of six videos called *What Does \_\_\_\_\_ Look Like*, based on EPRI reports about best practices for plant operators, such as the importance of having a questioning attitude for safe, efficient operations. The videos draw on knowledge and insights from thousands of

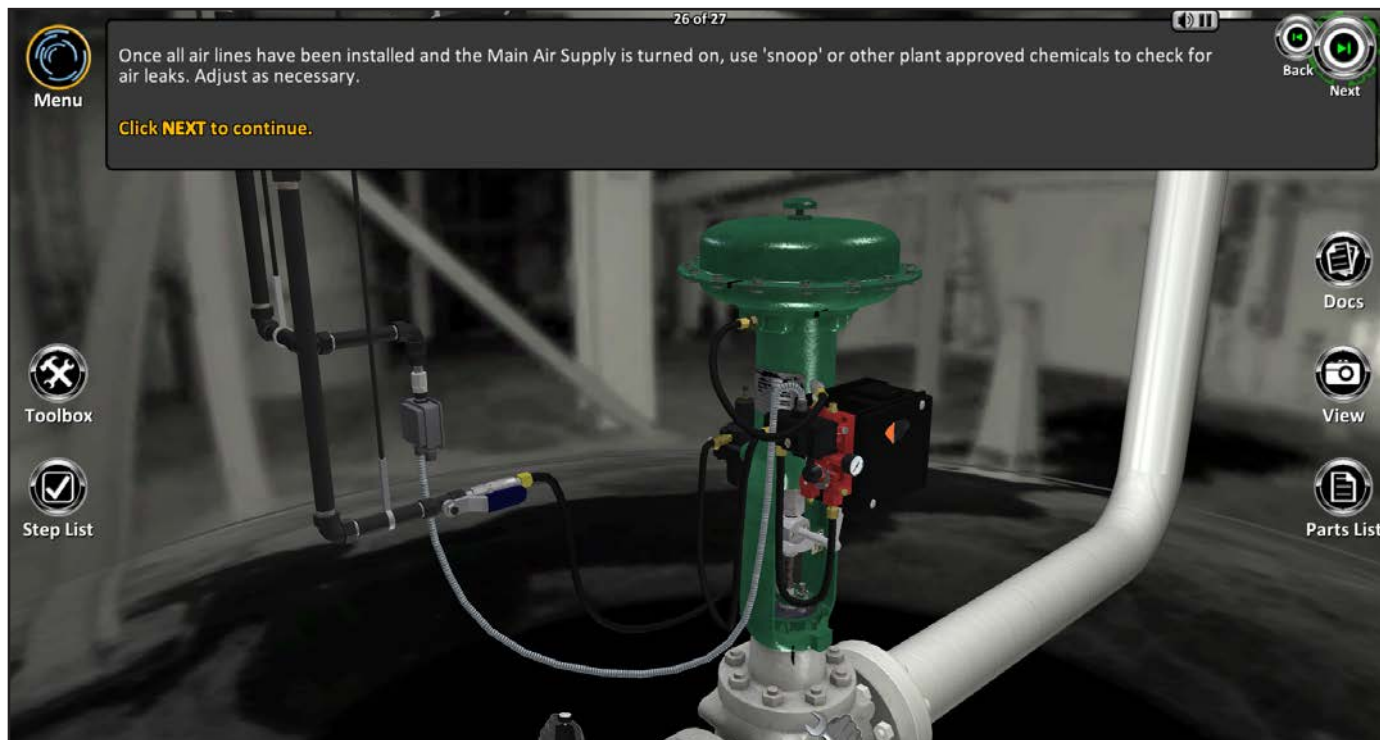

EPRI's air-operated valve app

pages of reports and present them in ways that can be readily helpful and useful. In the questioning attitude video, for example, viewers are prompted to stop and think when they encounter situations that stray from the norm. In one scenario, a plant worker notices a pool of water on the floor, then stops and contacts the control room to address the issue. “My group addresses the needs of people running the plant—the supervisors and the people turning the switches and valves,” she said. “They want the golden nuggets in the reports that can be pulled out for immediate value.”

Espinoza, Heishman, and other EPRI technical staff recognize that videos and apps can be more effective teaching tools for all generations. For Richard Pepin, an EPRI senior technical leader with decades of experience leading troubleshooting and repair teams in nuclear plants, there is no comparison between the AOV app—which uses 3-D animation and was built with video gaming technology—and the static paper manuals available previously. “In the past, I’d go through a troubleshooting repair with my engineers and senior craftsmen, and all we had was a flat drawing on a table. We had nothing else to work with,” said Pepin, who manages Nuclear sector knowledge transfer. “With an interactive app, you get to look at the equipment and the components at all different angles and slice and dice them. It’s incredible.”

## Capturing Knowledge, Responding to Industry Needs

Buck Gastinel laughed and smiled as he recounted how he got started in a career that would take him from installing air conditioning units in hotels to working in nuclear plants on large heating, ventilation, and air conditioning (HVAC) systems known as *chillers*. “I got started in HVAC very, very early,” Gastinel said to the camera in an EPRI video that has the look and feel of a friendly, informal chat with an uncle or grandparent. “Little did I ever realize I’d go this far in it. It was just a summer job, or a winter job, you’d do after school.”

Although accessible in tone, the 10-minute video interview with Gastinel has a serious purpose: to capture the industry veteran’s valuable insights and tips accumulated during a long career—most of it at the Comanche Peak Nuclear Power Plant in Texas. Gastinel recounted the early days of his career when the new chiller ran smoothly, allowing him ample time to study how it worked. “We had the options and opportunities to go into the chillers and learn them from the ground up,” he said, adding that this is not a luxury enjoyed today by new engineers and technicians working on aging equipment. Gastinel discussed how to interpret readings on the chiller’s digital display and provided maintenance tips for older equipment.

Whether it’s a video interview with a

chiller expert or an app to assist with AOV work, the topics EPRI highlights in knowledge transfer initiatives are not chosen at random. The objective is to contribute to improved plant safety and reliability. “There are three main factors we look at when determining which apps and videos to develop and the most appropriate delivery platform: industry trends, equipment found in most plants, and complexity of the maintenance task,” said EPRI Technical Leader Nicholas Camilli, adding that these factors made the choice to create the AOV app easy. “A power plant has hundreds of AOVs on safety- and non-safety-related equipment. There was an industry initiative to improve AOV performance, so it made sense to develop an app as a resource for craftsmen and engineers.”

A similar industry need led to EPRI’s development and 2014 release of a circuit breaker app. Among the world’s most common power plant components, the medium-voltage circuit breaker made by German company ABB is also exceptionally complicated, making repairs and training challenging. “There are roughly 1,500 parts in a component that measures two square feet,” said EPRI Principal Technical Leader Rick Way. “When you overhaul the breaker, you end up with all those parts on the table and have to put them back together. If you don’t assemble one correctly, you have to strip it back down and start over.” Even knowledgeable technicians

### Selected Knowledge Transfer Products

**Air-Operated Valve Maintenance App** This interactive educational and demonstration tool guides work on air-operated valves in nuclear plants (App versions for [Windows](#) and [Android](#)).

**What Does Questioning Attitude Look Like?** This video demonstrates how power plant personnel can cultivate a questioning attitude for safe, reliable operations ([DVD](#)).

**What Does Peer Check Look Like?** This video provides an overview and examples of peer checks by plant personnel ([DVD](#)).

**Circuit Breaker App** This 3-D animated app demonstrates disassembly and reassembly of the commonly used K-Line 1600 circuit breaker ([App](#)).

**Welding Guide App** This interactive app provides guidance on welding best practices ([App](#)).

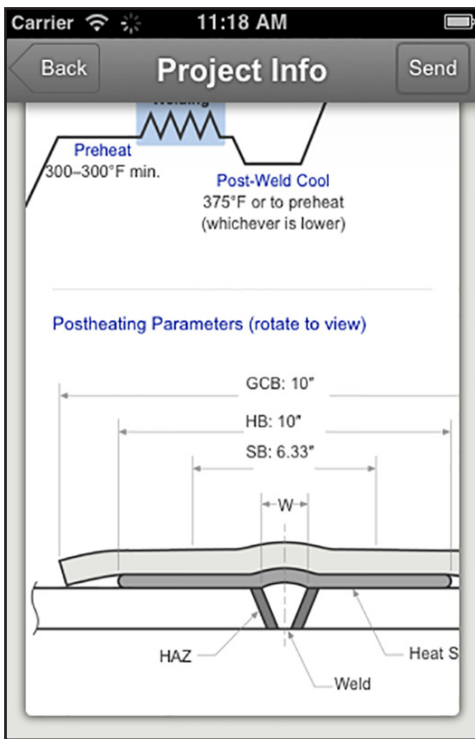

EPRI's welding guide app

can expect to spend a full eight hours on the task.

EPRI Senior Technical Leader Jim Sharkey worked with several nuclear plant technicians to design a circuit breaker app that provides helpful instruction to plant workers in the field. Unlike a manual with static drawings, the 3-D interactive app offers an educational virtual reality—allowing users to see how different parts fit together, manipulate them on the screen, and even watch a six-minute, step-by-step assembly of the entire circuit breaker. With the app, skilled technicians who haven't worked on circuit breakers in a while can get up to speed on best maintenance approaches much faster than if using a manual.

## Educating Both Students and Experienced Workers

According to Pepin, the circuit breaker app and similar tools can prepare students before hands-on training. "Every student waits for a chance to get into the training lab, and they waste a lot of time figuring out what they're doing," he said. "These tools can be used prior to the lab to show you what you're going to do, what you're going to see, and what outputs you can expect."

These applications are also designed to guide experienced workers in the field. An example: EPRI's web-based welding guide app for smart phones and tablets draws on a quarter-century of EPRI welding best practices research to help users complete their work safely and effectively. "You input the two materials you want to join together and the welding process you want to use," said John Shingledecker, an EPRI program manager. "Then the app gives you the EPRI recommendations on a number of factors, such as the filler metal to use, post-weld treatment, and cautionary notes from industry codes and standards." The app can be updated easily to incorporate code changes and the latest information on best practices.

EPRI's knowledge sharing work is already shaping how workers do their jobs. Consider Kim Musante, a long-time AOV engineer for PSEG at Salem Nuclear Generating Station and one of the 500 people who have downloaded the AOV app since its 2012 release. To address AOV problems in the past, Musante preferred to seek help from colleagues. "I talk to technicians who have been doing it for 30 years," she said. "That is the best information because they know the little tweaks." Though face-to-face lessons from veterans remain her favorite approach, the AOV app is not far behind as an educational tool. "With EPRI's software, it is like being out in the field with the guys," she said. "You can literally do anything—pick the tools, do testing, and take the valve apart. Even though I've been doing AOVs for a while, I learned some new things."

## The Future of Knowledge Sharing

As EPRI staff work more on storyboards, scripts, and other aspects of app development and video production, they gather insights on the art of digital knowledge transfer for the power industry. For instance, the AOV app was originally conceived as a video. But after filming a technician doing AOV maintenance, EPRI staff realized that video was not the right medium. Video shot from a first-person perspective was hard to follow and understand. Instead, Way and Pepin used the

information captured on video to develop a more user-friendly app.

In making the six videos on power plant best practices, Neva Espinoza learned that it was better to use plant employees rather than hiring actors. "This adds immediate credibility for the people watching it," she said.

Videos and apps won't completely replace in-depth research and reports. Indeed, workers exposed to a subject via video or app are more likely to seek comprehensive information in reports. Jim Heishman envisions future EPRI reports full of videos, animation, and other interactive elements that help explain difficult or complex concepts. "The big question for EPRI in the next 40 years is, what will we be known for publishing?" he said. "How will we transfer knowledge and technology to a new generation? It's not going to be a static paper report."

*This article was written by Chris Warren. Background information was provided by Jim Heishman, [jheishman@epri.com](mailto:jheishman@epri.com), 704.595.2768; Richard Pepin, [rpepin@epri.com](mailto:rpepin@epri.com), 704.595.2889; and Rick Way, [rway@epri.com](mailto:rway@epri.com), 704.595.2679.*



**Jim Heishman**, a senior program manager at EPRI, leads research on improving nuclear plant maintenance, including strategies, process, and work management.



**Richard Pepin**, a senior technical leader in EPRI's Nuclear sector, focuses on the mechanical areas of nuclear maintenance applications,

Work Planning Users Group, Japanese Condition-Based Maintenance Users Group, and knowledge retention.



**Rick Way**, a principal technical leader in EPRI's Nuclear sector, focuses on maintenance strategies and innovative knowledge transfer techniques.



# Navigating Tricky Waters: EPRI R&D Provides Options for Fish Protection

FEDERAL WATER POLLUTION CONTROL ACT  
(33 U.S.C. 1251 et seq.)

To provide for water pollution control activities in the Public Health Service, the Environmental Protection Agency and in the Federal Works Agency, and for other purposes.  
Be it enacted by the Senate and House of Representatives of the United States of America in Congress assembled

## TITLE I—RESEARCH AND RELATED PROVISIONS

### DECLARATION OF GOALS AND POLICY

SEC. 101. (a) The objective of this Act is to restore and maintain the chemical, physical, and biological integrity of the Nation's waters. In order to achieve this objective it is hereby declared that consistent with the provisions of this Act—

- (1) it is the national goal that the discharge of pollutants into the navigable waters be eliminated by 1985;
- (2) it is the national goal that wherever attainable, the propagation of fish, shellfish, and wildlife and the use of the water be achieved by July 1, 1985;
- (3) it is the national policy that the discharge of pollutants into the navigable waters be prohibited, except insofar as such discharge may be necessary to meet the basic human health requirements of the population;
- (4) it is the national policy that the discharge of pollutants into the navigable waters be prohibited, except insofar as such discharge may be necessary to meet the basic human health requirements of the population;
- (5) it is the national policy that the discharge of pollutants into the navigable waters be prohibited, except insofar as such discharge may be necessary to meet the basic human health requirements of the population;

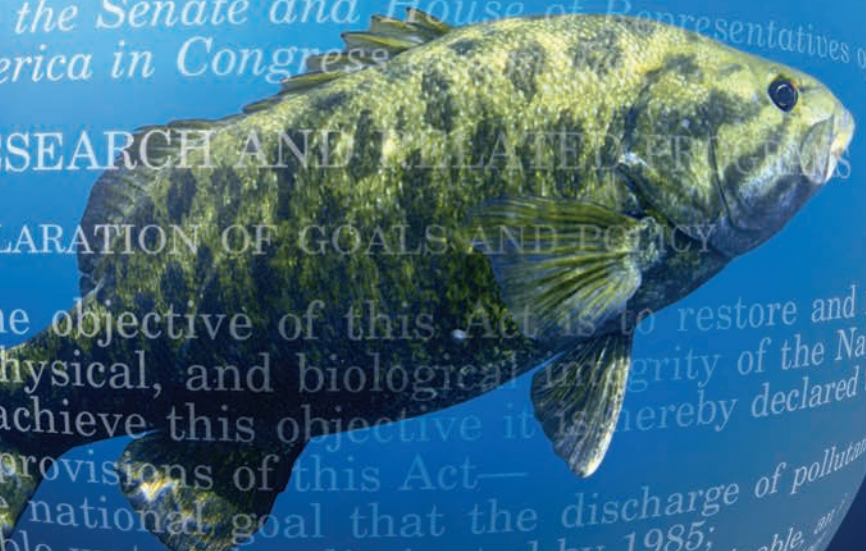

**O**n October 14, 2014, the clock started ticking for 544 U.S. power plants to comply with new environmental standards aimed at reducing harm to fish and shellfish from encounters with cooling water intake structures.

The U.S. Environmental Protection Agency's (EPA) final regulation implementing Section 316(b) of the Clean Water Act went into effect more than 40 years after the law itself. While the regulation's development required decades of research and discussion, affected facilities face requirements beginning this year.

The complex yet flexible regulation seeks to determine the best technology available to address two distinct mortal risks for fish and shellfish at all life stages: *impingement*, in which mostly larger fish get pinned against power plant water intake structures, and *entrainment*, in which early-stage organisms are pulled into cooling systems and threatened by heat, physical stress, and chemicals.

These two processes are responsible for killing more than two billion fish, crab, and shrimp each year, according to EPA.

For more than a decade, EPRI's Fish Protection Program has provided research results and technical assistance to plant owners and operators to help their facilities protect aquatic life, supporting EPRI's core R&D mission to make electricity more environmentally responsible. As part of this work, EPRI has kept EPA informed throughout its multiyear rulemaking process on the latest scientific, economic, and engineering information. Based on its research and compilation of findings, EPRI is optimally positioned to help the electric power industry navigate the multilayered compliance process.

"From the time EPA began to write a regulation on 316(b) in the mid-1990s until last summer, our research developed information to help regulators make a sound, science-based regulation. Our research continues, but we now offer assistance with implementing some of our results as well," said Doug Dixon, who manages EPRI's fish protection program.

## THE STORY IN BRIEF

Over the past decade, EPRI has published volumes of research on technologies and strategies to reduce the impact of power plants on fish and shellfish and has assisted plant owners and operators in protecting aquatic life from threats related to cooling water intake structures. Now this R&D will help them navigate EPA's new regulation on intakes under Clean Water Act Section 316(b).

EPA extensively cited EPRI's R&D in key technical background documents it prepared to support the rule. Because the regulation also reflects several main conclusions from EPRI research, it can serve as a valuable resource for plant operators.

An important EPRI finding is that environmental impacts of intake structures are as site-specific as the solutions.

"The impacts on fish and shellfish at plants on the Pacific coast are very different from the impacts on the Atlantic and Gulf coasts as well as in U.S. rivers and the Great Lakes. Where there are negative impacts, the fixes are site-specific and dictated by the facility's design, the type of water body and water flow, and the different aquatic species," said Dixon.

The regulation also reflects a related finding that many technologies are available for reducing harm. These include screens, nets,

acoustics that deter fish with noise, and closed-cycle cooling towers that reduce water flow and fish entering intake structures (see sidebar, p. 12).

### Flexible, Site-Specific Regulation

In line with EPRI's conclusions, the regulation allows for site-specific solutions, in contrast with previous versions of the rule that considered mandating cooling towers for all sites.

The regulation is divided into three main parts, each with specific requirements.

First, existing facilities that withdraw at least two million gallons of water per day from lakes, rivers, estuaries, or oceans, and that use at least 25% of withdrawn water to cool machinery—criteria that apply to all 544 power plants and 521 manufacturing facilities covered by the regulation—must



*A traveling water screen in a laboratory*

## Fish Protection Technology: Screens, Nets, Caps, and Towers

Since 2000, EPRI has published approximately 100 technical reports on fish protection R&D. Among the most important is a [reference manual](#) with detailed information on all known technologies for protecting fish from impingement and entrainment.

“The manual covers the universe of possibilities for compliance and the costs of implementing them,” said Program Manager Doug Dixon.

The most important technologies for compliance with EPA’s new regulation include:

**Closed-cycle cooling towers:** Cooling towers between about 50 feet and several hundred feet high recirculate, cool, and recycle water in a closed-cycle system. They enable facilities to significantly reduce water and fish intake but can cost hundreds of millions of dollars.

**Barrier nets:** The least expensive protection for fish, barrier nets encircle the area surrounding water intake structures. Given their typically large mesh size, they are more effective at preventing impingement of larger fish than entrainment of smaller aquatic organisms.

**Water screens:** Many types of screens collect fish and shellfish and return them to their water source. Traveling screens—the most common—are mounted in an intake structure on belts or chains that rotate to remove aquatic creatures. Cylindrical wedge-wire screens are stationary devices mounted on a central intake pipe.

**Velocity caps:** These structures, fitted on intake pipes located far offshore, have openings that naturally deter fish by changing the water flow direction. They are often combined with bars to prevent entry of larger marine mammals.

reduce fish impingement through one of seven options:

1. Operate a closed-cycle cooling system.
2. Reduce the maximum water velocity through screens—stationary or rotating types—to 0.5 feet per second during minimum source water levels.
3. Demonstrate velocity through screens of no more than 0.5 feet per second under all ambient conditions.
4. Have structures (known as *velocity caps*) at least 800 feet offshore that divert fish by changing the water flow direction at the intake openings. These should be combined with bars to prevent entry by marine mammals and sea turtles.
5. Install traveling water screens modified to improve fish survival by returning them to waterways, and optimizing performance for fish species classified by EPA as non-fragile in a two-year biological study.
6. Install an integrated system of technologies, practices, and operations—optimized for non-fragile species in a two-year study—and demonstrate mortality reductions similar to Option 7.
7. Show that impingement mortality has been reduced to no more than

24% annually for non-fragile species, based on monthly monitoring.

Second, facilities withdrawing an annual average of at least 125 million gallons daily have additional requirements for biological, engineering, and economic studies to determine technology options that reduce mortality from impingement and entrainment. According to EPA, this affects 30% of all 1,065 power plants and manufacturing facilities covered by the regulation. Doug Dixon estimates that this includes about half of the 544 covered power plants.

Third, new generation units that increase capacity at existing facilities must operate a closed-cycle cooling system or a technology capable of achieving entrainment mortality reductions within 90% of that achieved by closed-cycle cooling.

Facility owners and operators must have National Pollutant Discharge Elimination System (NPDES) permits to install, operate, and monitor selected technologies.

Plants with permits that expire after July 14, 2018 will begin compliance with their regular permit renewals. This will include collecting information on water bodies and aquatic species, producing studies, and selecting technologies. All permit application information is due 180 days before permits expire. For plants with NPDES permits expiring on or before July 14, 2018, owners or operators can set compliance schedules with their state NPDES permit director.

The rule does not include a specific deadline for installing impingement or entrainment control technologies.

### Implementing the Technologies in the Field

Continuing its many years of providing research results and technical assistance, EPRI will support power companies and the public with science and engineering research to navigate the biological, technology, and economic studies required by the rule.

One specific focus, according to Doug Dixon, will be to demonstrate how to complete required studies related to



A barrier net at NRG's Chalk Point Power Station in Maryland

enainment of fish and shellfish eggs and larvae. EPRI is developing an egg and larval identification database and DNA barcoding to support such studies.

"We are working to create a national database for identifying eggs and larvae of fish and shellfish and another database to help identify dead and moribund eggs and larvae," said Dixon. "These tools will help power companies more accurately quantify entrainment at facilities."

One regional effort is developing a database of eggs and larvae for the Ohio River. This will complement the EPRI-managed Ohio River Ecological Research Program, initiated in the early 1970s in response to the Clean Water Act's Section 316, which has resulted in the world's longest continuing freshwater database on the potential impacts of power plant water intake structures. A collaborative study showed that impingement and entrainment of fish and shellfish from water withdrawals on the Ohio River do not significantly impact fish populations.

Field experiences in collaboration with utilities will enable EPRI to produce several case studies highlighting key results and future research needs for both EPRI membership and the public.

"They are all works in progress," said David Bailey, who manages EPRI's 316(b) research including closed-cycle cooling retrofits. "Some are focused only on impingement issues, while others are also addressing entrainment."

EPRI R&D is providing timely answers to enable more cost-effective fish protection options for utilities, he said. Various reports will be published this year, including guidebooks, case studies, and overviews of technologies.

### How Much Will Compliance Cost?

EPA estimates the rule's total compliance costs at approximately \$300 million for both electric generators and manufacturers. Power plants under the rule's existing unit provision account for more than \$200 million.

These figures are dwarfed by EPRI's cost estimate for a previously considered version of the rule requiring all facilities to retrofit closed-cycle cooling towers: approximately \$95 billion. As part of EPRI research on cooling tower retrofits from 2007 to 2012, Bailey estimated that installing cooling towers would cost each facility between \$50 million and \$500 million, forcing many plants to retire.

### Rule Faces Legal Challenges, EPRI Research Continues

EPA's new regulation marks its third attempt over the past decade to establish requirements for existing facilities. Rules issued in 2004 and 2006 were challenged in court and sent back to EPA or withdrawn by the regulator for further consideration.

The current rule is again the subject of lawsuits filed by environmental groups arguing that it does not go far enough to protect aquatic life—and by industry groups contending that it goes too far.

According to Dixon, EPRI's fish protection research program is prepared to assist in any outcome, whether it's informing regulation again or addressing compliance.

"It's very hard to predict what's going to happen legally," said Dixon. "Right now we are focused on implementation, but our research on fish protection will continue. This includes monitoring technical developments, looking for opportunities to enhance the performance of existing fish protection technologies, and developing new ones that are cost-effective for the industry and the public."

*This article was written by Garrett Hering.*

*Background information was provided by Doug Dixon, [ddixon@epri.com](mailto:ddixon@epri.com), 607.869.1025, and David Bailey, [dbailey@epri.com](mailto:dbailey@epri.com), 703.978.6226.*



**Doug Dixon**, a technical executive and program manager at EPRI, manages research on fish protection issues, including development and evaluation of power plant intake fish protection technologies, aquatic impact assessment, field sampling and data analysis, cost-benefit analysis, habitat and fish stock restoration, and upstream and downstream fish passage.



**David Bailey**, a senior project manager at EPRI, manages research on closed-cycle cooling for fish protection and supports member efforts in

complying with the requirements of the new and existing facilities 316(b) rules, including analysis of fish protection technology alternatives, cost-benefit analysis, and non-water quality impacts analysis.

# Next-Generation Heat Pump: More Efficient, More Interactive





## THE STORY IN BRIEF

In 1945, inventor and local power company employee Robert C. Webber had a Eureka moment when he burned his hand on the back of his freezer. Inspired to action, he used a compressor, refrigerant, and a coil of copper wires to build a simple device that could extract heat from cold outdoor air and move it inside his Indianapolis house. In the summer, Webber reversed the process for cooling.

Today's electric heat pumps are conceptually similar to Webber's homemade model. By using electricity to move heat from one area to another, they can move two to three times more energy than they consume. They can heat cold rooms or cool hot rooms. Because they're simply moving heat, rather than burning natural gas or propane to generate it, they use a fraction of the energy consumed by fossil fuel-burning heat systems. The untapped energy savings potential is enormous: Given that heating and cooling account for 48% of U.S. residential energy consumption, converting the 63 million fossil fuel-heated American residences to heat pumps could potentially save consumers billions of dollars every year. Heat pumps also offer tremendous potential benefits for demand response because heating and cooling drive peak energy demand for most utilities.

Achieving mass adoption will require improving the heat pump's efficiency, heating ability in cold climates, and grid connectivity. Since 2009, EPRI researchers have focused on these aspects in developing a next-generation version. They are also addressing technical challenges related to frost buildup on heat pumps in colder climates. When looking across all climate zones, the potential market growth is significant: The U.S. Energy Information Administration reports that about 2% of northern U.S. residences use heat pumps, compared with 16% of residences in the U.S. Southeast (see map at right).

Gary Connett, director of member services and demand-side management at Great River Energy, is a believer in heat pumps. It's 40 degrees outside his office in



The heat pump has come a long way since British physicist Lord Kelvin first came up with the theoretical concept more than 150 years ago. With enhanced efficiency, heating ability in cold climates, and grid interactivity, EPRI's next-generation heat pump has the potential to yield enormous societal benefits by reducing energy costs, emissions, and peak demand.

Maple Grove, Minnesota, and the heat pump keeping him warm is operating at a *coefficient of performance* of 2.5—in other words, its heat energy output is two and a half times its electric energy input. Compare that with a traditional natural gas furnace, which converts 80–95% of the gas's energy content into heat energy. What if a heat pump could operate as effectively when the temperature dips another 20 degrees? “If I can get a heat pump that heats between 55 and minus 5 degrees, I've got huge parts of my service territory

covered,” said Connett.

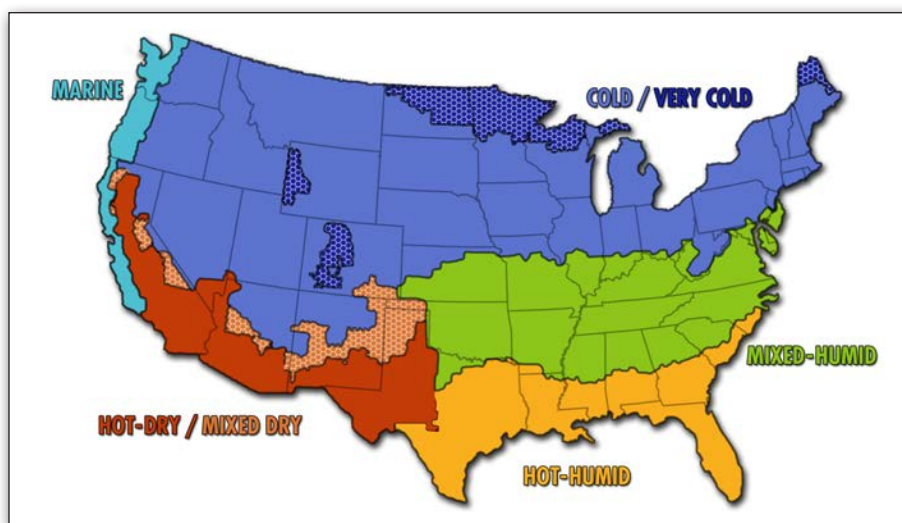
EPRI worked with a Colorado manufacturer to construct a prototype and in 2014 tested the unit at its Knoxville facility, with promising results. It demonstrated greater heating and cooling efficiency than the majority of installed heat pumps, and it responded to simulated utility demand response signals. Collaborating with heat pump makers, EPRI will build two versions of a second prototype: one with heating and cooling efficiencies a bit higher than current commercial



	COLD / VERY COLD	MIXED-HUMID	Hot-Dry / Mixed Dry	HOT-HUMID	MARINE	TOTAL UNITED STATES
 <b>Percentage of Homes with Heat Pumps</b>	2%	13%	6%	16%	6%	9%
 <b>Total Homes (Millions)</b>	38.8	35.4	14.1	19.1	6.3	113.6

Source: U.S. Energy Information Administration, 2009 Residential Energy Consumption Survey

models, and the other able to operate at higher efficiencies and in much colder temperatures. “If we’re successful, this heat pump should handle most U.S. weather conditions,” said Ron Domitrovic, who manages EPRI’s heat pump R&D.

### How the Next-Generation Heat Pump Works

The heat pump operates on a simple scientific principle: the temperature of a gas increases when compressed and decreases when expanded. In the winter, extremely cold liquid refrigerant in the heat pump’s outdoor unit absorbs heat from the warmer air, causing it to boil into a vapor (see diagram, p. 17). A compressor increases the refrigerant vapor’s pressure, raising its temperature and sending it through a coil to the indoor unit, where it is used to heat the interior. The refrigerant then expands and cools as it passes through a valve back to the outdoor unit—and the cycle repeats. In the summer, the heat pump works in reverse as an air conditioning unit, pumping indoor heat outside.

A key element of EPRI’s next-generation heat pump is its variable-speed compressor, which runs at any speed within a wide range depending on the load. Used for decades in large industrial machines such as pumps and air compressors, variable-speed compressors were first applied to air conditioning units in Japan in the 1980s. They operate more efficiently than single-speed compressors in traditional heat pumps that constantly cycle on and off. Because compressors account for about 75% of a heat pump’s power consumption, going to variable speed can have a huge impact on the device’s overall efficiency. “Imagine an infinite-speed bike that can adjust to any road condition,” said Domitrovic. “Our heat pump’s compressor is based on a similar concept, able to make tiny speed adjustments to match heating or cooling needs at any given moment for greater efficiency.”

In addition, the heat pump’s variable-speed compressor can produce more heat, aiding its performance particularly in

colder climates. With a single-speed compressor, *heating capacity*—the rate of heat delivered or removed from a space—is determined by its one speed. For example, the compressor may produce 10,000 British thermal units (BTU) per hour all the time, even if 20,000 BTUs per hour are needed on a colder day. A variable-speed compressor can deliver those 20,000 BTUs. “You can speed up the compressor to increase the system’s heating capacity,” said Domitrovic. “It can maintain heating capacity even as temperature decreases.”

This variable-speed capability enables more flexible demand response and load management. With single-speed heat pumps, the utility’s only option during peak demand is to cycle the systems on and off. Variable-speed systems can slow the compressor by any amount to achieve a range of demand response.

The remaining 25% of the energy needed to run today’s heat pump powers the fans that move air through the system. Researchers are evaluating various indoor and outdoor fan blade designs that run more quietly and efficiently. “You can potentially change one fan and cut the power by 20 watts,” said Domitrovic.

### Making the Heat Pump More Grid- and Cold Climate-Friendly

EPRI’s heat pump is designed to enhance grid interactivity. With traditional heat pumps, utilities send a one-way signal to override a thermostat and shut off the unit. The next-generation heat pump will enable two-way communication between utilities and systems for more flexible peak load management. For example, a utility could signal a unit to reduce power during peak demand, and the heat pump would respond with a 20% power reduction and then communicate the change to the utility. EPRI built the first prototype according to standard Open Automated Demand Response (OpenADR) 2.0 protocols.

“Integration with the grid is a key component of any technology,” said Chris Gray, a research engineer at Southern

Company, which has been developing heat pump technologies since the 1960s and is working with EPRI on the next-generation heat pump. “In our service territory, HVAC [heating, ventilation, and air conditioning] represents approximately 50% of consumer energy costs. The ability to interact with the grid benefits both the consumer and the utility.”

For cold climates, EPRI is addressing the technical hurdle related to frost formation. Below freezing, frost forms on the outdoor heat exchanger, creating an insulating blanket that blocks air flow and forcing the system to work harder to extract heat. When the unit ices over completely, a frost mitigation system reverses the refrigerant flow (acting as an air conditioner), heating the coils and melting the ice. In extremely cold climates, this could happen every 60 to 90 minutes.

Super-hydrophobic coatings can potentially repel frost from heat pump surfaces, but such coatings are better at repelling water than solid frost. EPRI is exploring a possible solution: briefly defrost the heat pump, forming a layer of water on its surface and causing the rest of the ice to slide off.

A second approach is adopted from supermarket refrigeration systems and involves rerouting a small amount of hot refrigerant from the compressor to the outdoor heat exchanger. EPRI is investigating more energy-efficient ways to do this, such as defrosting portions of the heat exchanger rather than the entire unit at once. Researchers have demonstrated that this approach can adequately defrost the heat exchanger and will measure its impact on the heat pump’s efficiency.

Another modification for cold climates relies on a gas furnace as a backup heating system during the coldest periods.

EPRI’s second prototype will test other useful features, such as internal temperature gauges to flag low refrigerant levels, probes to signal a loss in air velocity caused by a malfunctioning fan or clogged coil, and customer alerts when these problems occur.

# How the Next-Generation Heat Pump Moves Heat

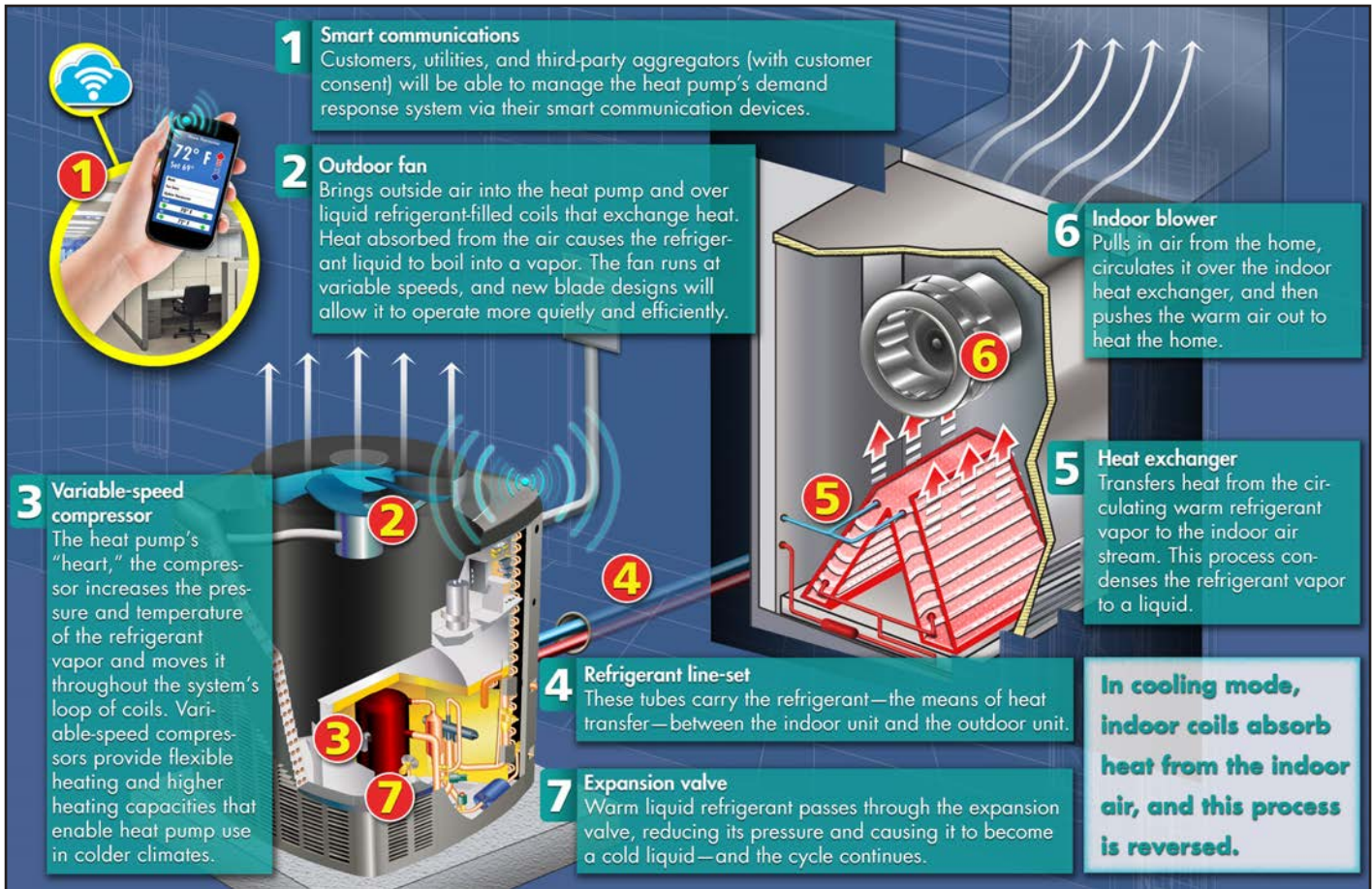

## Second Prototype and Field Demonstrations

After completing thermal testing on the first prototype last summer, EPRI researchers were encouraged by the unit's heating capacity and efficiency. They are now evaluating its ability to incorporate various communications standards, including Open ADR, SEP 2.0, and CEA 2045.

In 2015, EPRI will work with several manufacturers to build the two versions of the second prototype. The next step is field demonstrations with manufacturers and utilities in various regions of the United States. The utilities will identify appropriate customer residences and examine heat pump performance over the course of a year.

EPRI's next-generation heat pump points to important benefits for utilities. According to George Gurlaskie, technology evaluation manager at Duke Energy in

Florida, it could help solve challenges related to winter peak demand in his region. Its variable-speed compressor could help eliminate peaks that result when traditional heat pumps, because of their more limited heating capacity, engage less efficient auxiliary electric strip heat. With its demand response capabilities, it could also accommodate a utility's signals to preheat residences before traditional morning peak demand.

"We want to help utilities be more effective in encouraging consumer adoption of energy-efficient technologies," said Mark McGranaghan, vice president of EPRI's Power Delivery and Utilization research sector. "This technology is exactly in the sweet spot where utilities can make a difference."

*This article was written by Robert Ito.*

*Background information was provided by Ron Domitrovic, [rdomitrovic@epri.com](mailto:rdomitrovic@epri.com), 865.218.8061.*



**Ron Domitrovic** a program manager at EPRI, guides research on end-use energy efficiency, with a focus on air conditioning, refrigeration, and thermal systems in buildings.

# R&D Quick Hits

## A Quest for One Source of Truth on Outages

At the DistribuTECH conference in February, EPRI and its collaborators demonstrated a way to provide consistent outage data to the public following major storms and disasters, with the potential to enhance coordinated recovery in multiple service territories.

In the wake of Hurricane Sandy and similar events, attention turned to the difficulty of communicating accurate, timely outage information when dealing with multiple utilities' data formats and systems. Responding to a challenge from the White House Office of Science and Technology, an industry effort formed to develop standardized outage data.

At DistribuTECH, EPRI and seven vendors merged data from five utilities into an easy-to-understand outage map and broadcast it in real time to state and local government, radio and TV, and utility social media channels.

In the next phase, project collaborators will demonstrate how to improve disaster response by securely sharing detailed outage data with police, fire, and emergency medical services.

Other participants include AGSI, Baltimore Gas & Electric, Boreas Group, DataCapable, Duke Energy, ESRI, Google, iFactor, National Grid, Omnetric, San Diego Gas & Electric, Siemens, Southern California Edison, and U.S. Department of Energy.



## A Cost-Competitive Approach to Reduce Coal Plant Mercury Emissions That Starts with... Coal

Sometimes the solution to a challenge is sitting right under your nose—or, in the case of mercury emissions control, in a coal-fired power plant's own coal stockpile.

Activated carbon injection is among the most effective mercury control technologies, but it's expensive, costing \$1–10 million per year for a plant to purchase the carbon from suppliers. EPRI, Great River Energy, and American Electric Power have field-tested the sorbent activation process, which uses on-site coal to produce activated carbon for injection into a plant's flue gas to capture mercury.

Initial analysis of the demonstration results indicates that on-site sorbent activation can use various lignite coal feedstocks to produce activated carbon of quality similar to commercial sources. Plants requiring more than 500 pounds of activated carbon per hour can save approximately \$1–2 million per year.

The demonstrations also confirmed that the process can reduce mercury emissions below the stringent federal Mercury and Air Toxic Standards (MATS) limits, though long-term operational data are still needed to confirm the technology's commercial viability. EPRI and the University of Illinois at Urbana-Champaign developed the technology, and the power companies helped build full-scale devices for the tests. The EPRI report on this work is available for download at <http://epri.co/3002004294>.



### What Do EPRI, Coke, and San Diego Have in Common? Hint: It's in the Water

The U.S. Water Alliance in January awarded EPRI's Water Quality Trading Project its 2015 United States Water Prize, which honors individuals and organizations making outstanding innovations to advance collaborative, sustainable solutions to national water challenges. Also recognized were The Coca-Cola Company and the City of San Diego Public Utilities Department.

The project is developing mechanisms for power companies, other private and public organizations, and individuals to purchase water pollutant reductions from farmers to achieve water quality goals. It is the world's largest such trading project. In 2014, it completed its first trades between farmers and power companies in the Ohio River Basin, demonstrating trading's feasibility and collecting accolades from the U.S. Environmental Protection Agency, U.S. Department of Agriculture, environmental groups, and other stakeholders. For more information, visit [wqt.epri.com](http://wqt.epri.com).



### Less Is More: Making Nuclear Plants Safer with Fewer Inspections

Based on U.S. nuclear power industry data over the past 10 years, EPRI-developed methodologies for more targeted in-service inspections of plant components have cut inspection costs by 70% and worker radiation dose by 85%.

Historically, nuclear plant operators have used American Society of Mechanical Engineers (ASME) or equivalent codes to guide in-service inspections for identifying component degradation that can lead to failure. Because such approaches do not always consider actual plant operating conditions, causes of component degradation, and consequences of failure, plant staff may spend significant inspection time on locations that experience little stress—and they may not inspect in all the right places.

For more than a decade, EPRI has been advancing a risk-informed in-service inspection methodology that takes such factors into account, focusing maintenance resources on the most safety-significant inspections. Using the risk-informed approach, operators inspect components exposed to rapid temperature change or contaminants that make degradation more likely. The methodology also helps them identify cost-effective safety improvements that reduce inspection burden, such as relocating piping to less sensitive plant areas, installing flow-restricting openings, and revising operating procedures. The result? Lower costs, lower worker radiation exposure, and safer plants.

Now codified by ASME and approved by the U.S. Nuclear Regulatory Commission, the methodology has been adopted by most U.S. nuclear plants. In addition, EPRI is helping nuclear operators in other countries incorporate the risk-informed approach.

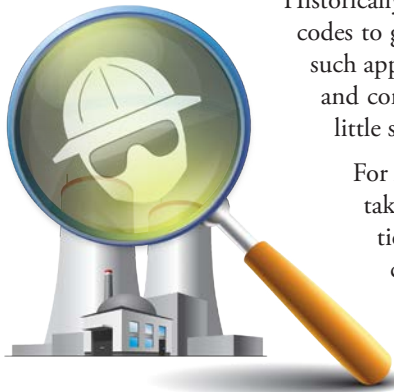

### When Wet Meets Dry: Power Plant Cooling Technology Demonstrates 38% Water Savings

In a nine-month pilot test, a hybrid cooling technology for fossil power plants known as the Eco Wet-Dry Cooler (Eco-WD) demonstrated an average water savings of 38%. The tests were conducted at the Water Research Center—a Cartersville, Georgia power generation water research facility supported by an EPRI-led research collaborative of utility companies. The Eco-WD is designed to reduce evaporative water losses during cooling, which account for most of a power plant's water consumption.

Developed by Evapco Inc., Eco-WD is a hybrid cooling system, with a wet mode typically used for cooling during warm summer months and a water-conserving dry mode for the rest of the year. The water cools as it flows through two coil systems in series. Dry cooling occurs as a fan pulls air over the coils, and wet cooling involves spraying water over the second coil system. Eco-WD's hybrid design equips the system to operate in complete dry mode when ambient temperatures are low.

With the demonstrated strong potential for commercial application, the next step is to evaluate a larger scale unit at an operating power plant over a longer time and changing weather. The EPRI report on this study is available for download at <http://epri.co/3002001595>.



# Cultivating a Culture of Safety: A Century of Progress in Electric Power



**M**any utility linemen were mad as hornets when first required to wear fiberglass hard hats in the 1940s. They were a tough fraternity of skilled workers, with favorite hats, lucky hats, and fraternal hats made of felt, leather, or wool. While fiberglass was safer than electricity-conducting steel and aluminum hard hats used in mining and construction, linemen didn't like change and took pride in mastering risk. Seven decades later, they embrace hard hats without question and vigorously pursue safety in all aspects of their work.

As an icon of safety, the hard hat reflects the parallel progress of safety innovations and safety culture in electric power. Last year marked the 100th anniversary of the National Electric Safety Code (NESC), prompting *EPRI Journal* to review nine key safety innovations gathered from experts in utilities, government, R&D, and academia. They cover public safety (including the environment), personal safety, and ensuring safe operations of nuclear plants in light of their unique radiological characteristics.

## 1. Foundations of Safety

After 30-plus years of independent entrepreneurship in electric power, the U.S. federal government in 1914 incorporated best safety practices and accumulated technical knowledge in the NESC. "The U.S. Bureau

of Standards convened the industry to talk about safety, in the millions of houses being wired and the electric system that served these houses," said Mike Hyland, senior vice president of engineering at the American Public Power Association and NESC Chairman. "The Bureau came out with codes for grounding, loading distribution lines, establishing clearances, and more. While the Bureau got input from experts, it wasn't a consensus code. They acted like a regulatory body."

It took another 50 to 60 years for the government to reevaluate its safety role. "The Bureau held a series of meetings in the 1960s in which rulemaking became an industry-consensus process for the first time," said Hyland. "By the early 1970s, it gave all the indoor parts of the code to the National Fire Prevention Association (NFPA) and all the outside parts to the IEEE, which became the NESC secretariat." The NESC is now a world standard, used in more than 100 countries.

With its evolving role, the federal government in 1971 created the Occupational Safety and Health Administration (OSHA), focused on the workplace environment in industries ranging from energy and construction to manufacturing and transportation.

## 2. Protective Devices

Devices that protect people and equipment

from electrical faults, surges, and overloads have advanced from simple sacrificial devices to elemental fuses to today's sophisticated lightning arrestors, surge protectors, relays, and circuit breakers. Historian Joseph Cunningham, whose book *New York Power* traces early 20th century development of power in Manhattan, assigns great credit to Thomas E. Murray for pioneering safety through protective devices and procedures. Murray was awarded more than 462 patents, from safety improvements to screw-in fuses. "Murray had this almost religious view of the safety responsibility of electrical companies and manufacturers," said Cunningham. "He insisted on safety in everything from home appliances to Christmas light sets." Murray and his companies were the first to push the development of electrical safety devices, such as wiring techniques, fuses, and combination fuse-and-switches known as *cut-outs*.

By mid-century, "grounding the shell of appliances and power tools through the creation of the third prong had taken hold," said Cunningham.

As a seminal development in electrical safety, David Wallis, former director of OSHA's Office of Engineering, singles out the ground-fault circuit interrupter (GFCI). "If this were my list, the GFCI would be number one. It was probably the single biggest lifesaver in my years at OSHA." Invented in 1961 by U.C. Berkeley Electrical Engineering Professor Charles Dalziel, the GFCI is ubiquitous today. According to OSHA data, between 650 and 1,100 deaths have been prevented after an OSHA mandate in the 1970s that GFCIs be used for "temporary wiring" on construction sites.

## 3. Protective Clothing and Gear

In the past 20 years, the primary standard-setting bodies—NFPA, NESC, and OSHA—have moved aggressively to require electrical workers to wear fire-resistant and arc-rated clothing around energized lines and equipment. According to OSHA, "Electric arcs pose some of the



A line worker using a hotstick. Photo courtesy of NRECA.

most serious safety hazards for electric power industry workers” because they can generate high temperatures, intense pressure waves, and shrapnel from vaporized and molten metal particles. Recently, arc-rated and fire-resistant clothing has become more comfortable, according to Wallis.

Other key life-saving advances for live-line work include rubber insulating gloves and hot sticks (insulated poles). “The newer Class-00 gloves are much better. You can wear them up to 500 volts, and they’re a little thicker than the Playtex gloves you use to wash dishes,” said Wallis. “Even more important than gloves are the fiberglass live-line tools that in recent decades replaced the wooden hot sticks.”

#### 4. Network Stability

Reliable grid operation requires that power production continuously balance demand. Imbalances lead to changes in the electricity’s frequency, which if excessive can undermine stability and lead to equipment damage and blackouts.

Today, more than 100 Balancing Authorities in the United States monitor grid frequency in real time with advanced sensors known as *phasor measurement units*. By analyzing sensor data with software, they can identify problems before they impact safety and reliability.

But this wasn’t always the case. “Because of difficulties with frequency control, network stability plagued the industry for decades,” said Julie Cohn, a University of Houston researcher specializing in U.S. power system history. In the early 1900s, system operators detected frequency changes by collecting multiple measurements over time with meters. “Coordination among operators was hindered by the growing operating data,” added Cohn. “They did all the calculations by hand and relied on telephone communications. All this made managing interconnections in real time extraordinarily challenging, compared to today’s rapid data processing and communication.”

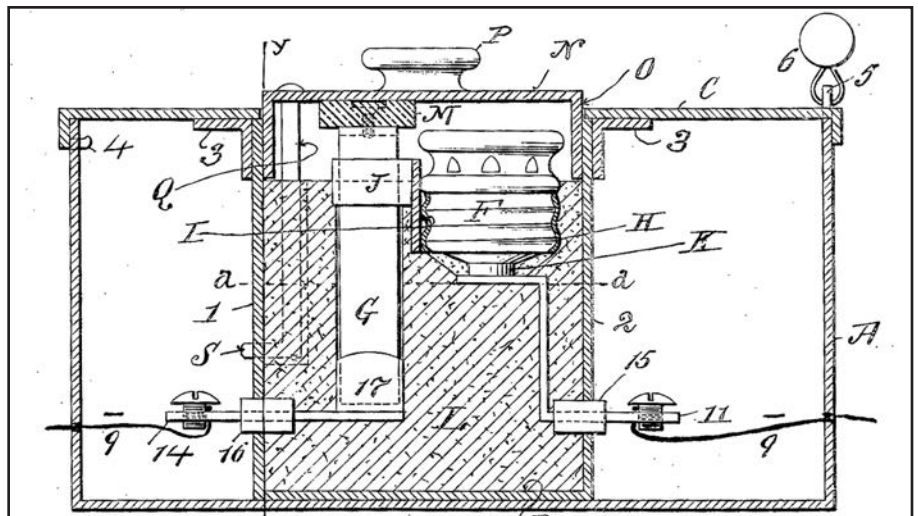

A drawing of an electric cut-out from a patent application filed by Thomas Murray in 1917. (For more Murray patents, see [www.temurray.com](http://www.temurray.com).)

#### 5. Probabilistic Risk Assessment

Pioneered in the mid-1970s, probabilistic risk assessment has contributed significantly to nuclear plant safety. Chauncey Starr, EPRI’s founder and first president, recognized its potential value in the 1960s. “It provides a systematic process to examine the entire plant and its processes and identify what can go wrong, how likely it is, and what the consequences can be,” said Stuart Lewis, EPRI senior program manager. “It offers a unique context for understanding the human role in accidents. The detailed understanding and probabilistic perspective help to focus resources on the most effective improvements.”

Prior to risk assessment, nuclear plant design focused on mitigating a set of accidents prescribed by regulation, such as a guillotine break of a large pipe. “Three Mile Island highlighted the need to go beyond this approach,” said Lewis. “This severe accident resulted from a series of relatively modest equipment failures and human responses, and had no elements of the traditional accidents that shaped the plant’s design. Probabilistic risk assessment follows a process to capture these cascading and interrelated events.”

#### 6. Nondestructive Evaluation

For decades, detecting metal fatigue, crack initiation, and hidden corrosion has relied

on X-rays, ultrasonics, and other nondestructive evaluation technologies for predicting and preventing catastrophic failures and reducing injuries in the power industry. These technologies also are instrumental in ensuring safe nuclear plant operations.

Dan Rossero, FirstEnergy director of generation safety and human performance, recounted a classic story on the technology’s value: “When I was running a coal-fired generating plant in Ohio, there was an industry problem with failures in boiler supply tubes in the dead air space underneath the bottom ash slopes. We worked with EPRI and nondestructive evaluation contractors in 2013 to inspect these supply tubes using digital X-ray technology to make sure we didn’t have the same mechanism at work. Through the inspection, we identified a number of supply tubes with this problem and were able to replace them.”

To enhance the benefits of nondestructive evaluation at nuclear plants, EPRI has advanced a risk-informed inspection methodology that focuses inspections on the most risk-significant areas, such as components exposed to rapid temperature changes. This methodology, now adopted by most U.S. plants, has reduced inspection costs by 70% and personnel radiation exposure by 85% while increasing reactor safety margin. Advances in inspection tech-



nologies have enabled practitioners to evaluate a wider variety of materials more completely, improving plant safety.

## 7. Process Control and Simulation

In the 1960s, advances in computing power enabled fossil generation process control of fuel, combustion, steam, and power systems to move from analog to digital models. Although the primary objectives were reliability and efficiency, FirstEnergy's Rossero sees the outcome in terms of safety. "Today's computer-based control systems allow you to keep your operating parameters within tighter bounds and eliminate excursions of temperature or pressure that could lead to problems."

A related advance is computer simulation of process control. "Previously we had a limited manual control board for operator training known as a benchboard," said Rossero. "During the last few years, we've enhanced our training by installing high-fidelity simulators that fully model how a unit will react to operator decisions. We've made it standard protocol to vet large engineering control changes through our simulator before putting them into a live unit."

## 8. Passive Nuclear Plants

Four years after the 1979 Three Mile Island accident, EPRI's Nuclear Vice President, John Taylor, sent a letter to utility CEOs asking what it would take for them to consider nuclear again. "The majority said they wanted a plant with simplicity in all aspects of design, construction, and operation—and with large design margins to make it forgiving and rugged," said Albert Machiels, EPRI senior technical executive.

EPRI collaborated with more than 30 utilities and the U.S. Department of Energy's Advanced Light Water Reactor (ALWR) Program to develop the Utility Requirements Document, which detailed design requirements for a new generation of ALWR plants emphasizing safety, simplicity, standardization, and reliability. These designs incorporated safety features using passive means such as gravity and natural circulation for water injection, cooling, and other functions, giving

## Average Injury/Illness Rates in the Electric Power Industry

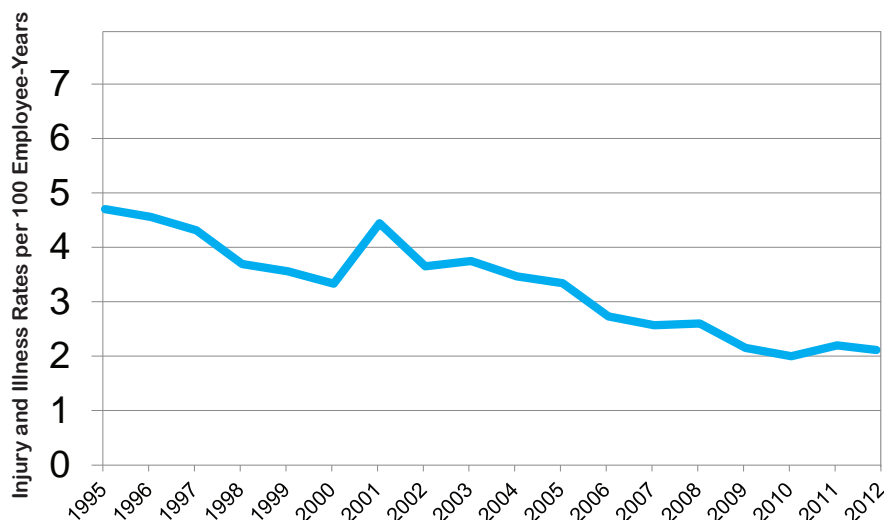

Source: Electric power industry data, based on information from 18 companies, are from EPRI's *Occupational Health and Safety Database 2013: Annual Data Reporting Years, 1995–2012*.

operators more time to respond to abnormal conditions compared with existing light water reactors.

This industry program funded U.S. Nuclear Regulatory Commission (NRC) design certification of three passive plants: the General Electric Advanced Boiling Water Reactor, the CE System 80+, and the Westinghouse AP600 (which was the basis for the current Westinghouse AP1000 design, also certified by the NRC). Subsequently, GE-Hitachi received NRC certification for the Economic Simplified Boiling Water Reactor.

EPRI recently released revision 12 of the document, with safety updates based on lessons from the Fukushima accident and updates for small modular reactors, which also use passive systems.

## 9. Safety Culture

"A defense-in-depth strategy for electric power safety emerged from a combination of efforts in the 20th century," said NESC Chairman Hyland. "OSHA, NESC, and the NRC created a solid foundation, and utilities built on that with their safety manuals, safe work practices, guides, books, and programs."

In the 21st century, Hyland and others in the industry point to a growing culture of safety led by a generation of workers who embrace new technologies, behaviors, prac-

tices, and procedures in ways distinct from previous generations. In the 1940s, line workers free-climbed poles and often resisted wearing rubbers over their boots. Today free-climbing has been discarded, and workers readily wear fall-restriction devices and high-insulation gloves.

Data showing a long-term drop in electricity-related injuries and illnesses (see graph above) reflect this progress. Building on these advances, EPRI in 2015 established the Safety Research Center of Excellence to spearhead safety research and spread safety-related expertise among the power industry's various disciplines.

*This article was written by Brent Barker.*

FIRST PERSON *with Jim Scarola*

---

# The Path to Global Energy Security: A Nuclear Perspective

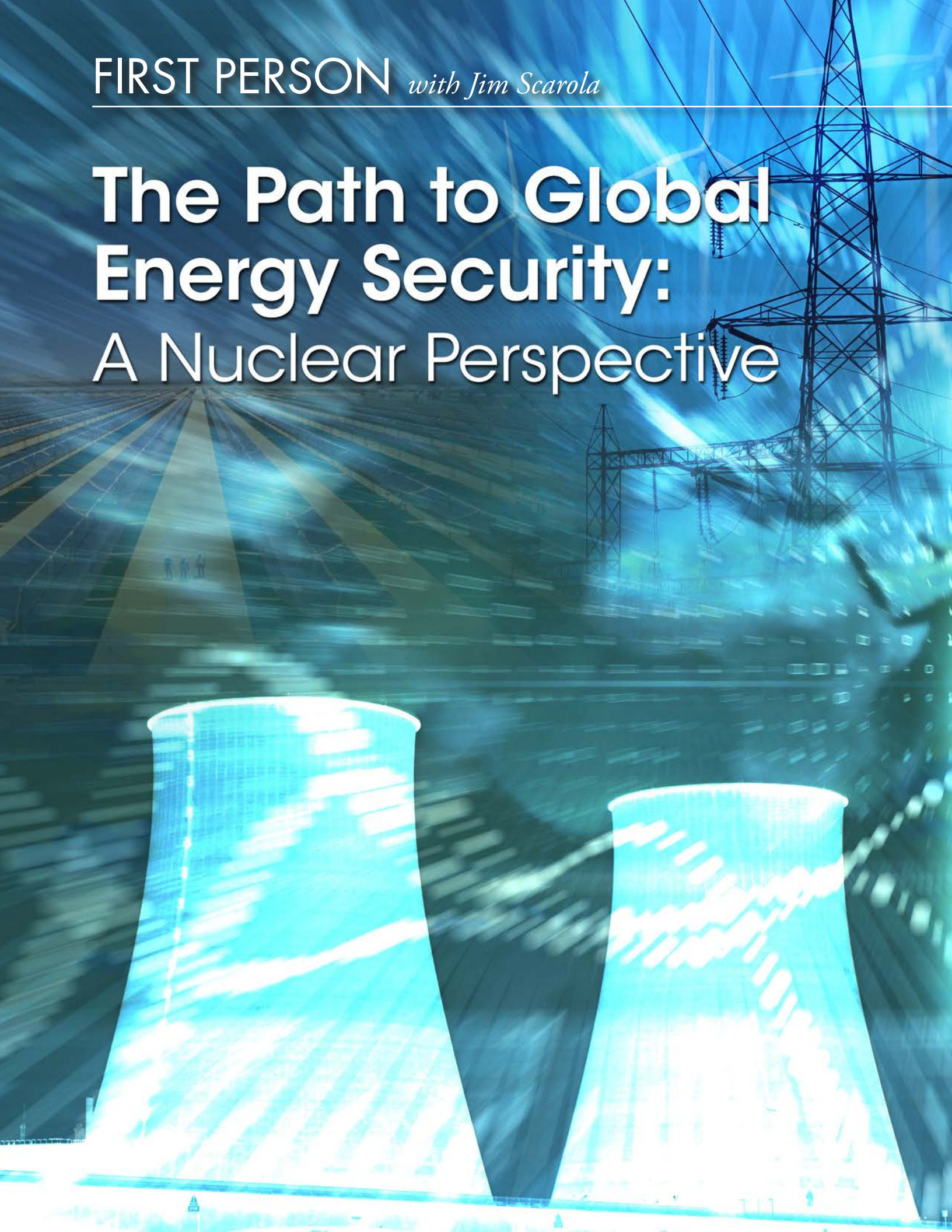

Since retiring as chief nuclear officer of Progress Energy in 2013, Jim Scarola has played a leading role on the Fukushima Response Steering Committee. In this interview with *EPRI Journal*, Scarola talks about the importance of advancing the right behaviors, standards, and technologies to support global energy security and public safety.

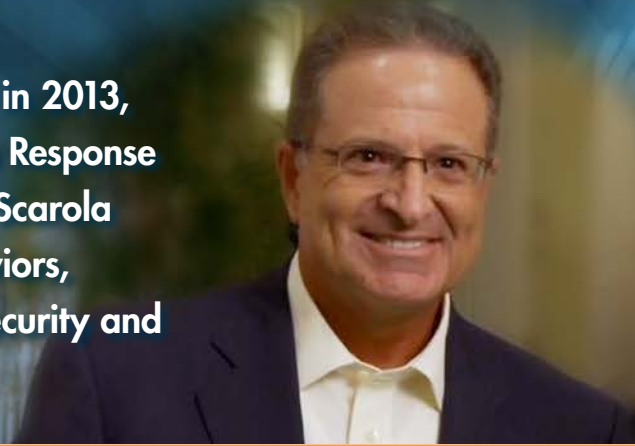

**EJ:** *The Fukushima Daiichi event has profound implications for the global nuclear power industry and for the security and safety of our power infrastructure. Let's begin with your role on the Fukushima Response Steering Committee. Describe the committee's objectives and activities.*

**Scarola:** The steering committee was formed immediately after the Fukushima event. The tsunami took place on a Friday afternoon, and by Saturday every utility CEO and chief nuclear officer in the United States met on a conference call with NEI [Nuclear Energy Institute], INPO [Institute of Nuclear Power Operations], and EPRI to coordinate the industry's roles and activities in the weeks ahead. The committee first focused on information flow, then turned to what assistance was needed and how to coordinate that assistance. People were dispatched to Japan, and emergency procedures from similar U.S. plants were provided to assist the Daiichi staff. Then the focus shifted to gathering facts and extracting lessons that could inform actions to improve technical and human readiness for potential future events. This comes from an ingrained nuclear industry

philosophy to learn from operating experience throughout the world. Part of the steering committee's role was to focus on those lessons from Fukushima that provide the greatest benefit for public safety.

**EJ:** *Which lessons proved most important?*

**Scarola:** The most significant lesson was the value of diversity—in other words, making sure plants have many possible paths out of a challenge. This came from a realization that Fukushima Daiichi was overwhelmed by conditions that were not anticipated. Nuclear plants have redundant safety systems, but they are designed based on a common set of predicted events that consider plant siting, hundreds of years of geological data, and other sound science. How do you prepare for an unanticipated event? You may consider making the wall around your plant higher to protect against a tsunami. But if I tell you that the event may be a tornado or a meteor rather than a tsunami, you may start thinking differently. Instead of a narrow focus on a higher wall, you're now talking about a different approach. You define your objective—cooling the

reactor core—and then figure out diverse ways to achieve that.

This diversity approach drove the creation of the FLEX strategy, one of the committee's key actions. This involves placing emergency equipment in multiple plant locations—and also staging portable equipment in several off-site locations for transportation to the plant for mitigation and recovery operations.

The second important lesson has to do with human behavior. While we continue to focus on improving technology, we also have to recognize the need for a set of behaviors that we refer to in the United States as safety culture. This comes from an attitude that you're never satisfied with the current state of operations and that you must continue to learn lessons to make operations tomorrow better than they are today.

**EJ:** *In testimony last year, you briefed the U.S. Nuclear Regulatory Commission on Fukushima lessons, and you emphasized that relationships are critical to mitigating extreme events. Please elaborate on this point.*

**Scarola:** This lesson came out of the experience at Fukushima Daini, the nuclear plant located several miles south of Daiichi. The Daini plant faced significant challenges in the aftermath of the tsunami, but plant operators maintained core cooling and safely shut down all the reactors. Why was there a different outcome than Daiichi? We found very strong relationships built by the senior leader not

"Advanced technologies are critical to supporting energy security worldwide, but clearly only when their use is supported by the right standards and safety culture."

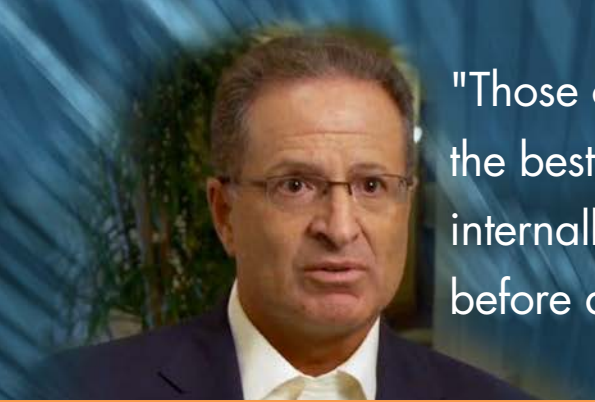

"Those of us who have led nuclear stations understand that the best time to establish relationships and build trust, both internally in the organization and with a community, is long before an event occurs."

*Photos of Jim Scarola courtesy of Justin Lee, INPO Communications Services*

only with his own operating staff, but also with the organizations that he relied on regularly for support—vendors and contractors with essential skills. So when he asked for assistance or was providing direction under very stressful conditions, those organizations responded well and with urgency.

At a recent workshop I attended, a very seasoned emergency planning manager said, "You never want to find yourself in an event having to pass out business cards to introduce yourself." Those of us who have led nuclear stations understand that the best time to establish relationships and build trust, both internally in the organization and with a community, is long before an event occurs. With that trust, your employees, your contractors, and your community will have confidence that you are leading the plant in the right direction.

***EJ: What is challenging the security of the global electric power industry?***

**Scarola:** Today we have a different supply mix. Gas is much more available. New nuclear deployment and advances in wind and solar are shifting the energy picture. A particular concern is the rapid electric demand growth in nations such as India and China with the financial resources to deploy advanced nuclear technologies. Growth in the use of nuclear technology requires the right supporting standards and safety culture. The absence of these can lead to events with detrimental global impacts. The events at Fukushima have once again reminded us that the use of nuclear technology is directly tied to public confidence. Fukushima threatened

public confidence in nuclear energy and its future use. We see the direct impact in Japan where its entire nuclear fleet remains shut down even after major upgrades—and indirect impacts in places like Germany that now look to alternate energy sources to serve their electric demand. Advanced technologies are critical to supporting energy security worldwide, but clearly only when their use is supported by the right standards and safety culture.

This brings into focus the role the United States and others must play to ensure that nuclear technologies come into service in a safe manner. The standards and culture in our operating programs emerged over a long time through a tremendous infrastructure, including the U.S. nuclear navy, research at national laboratories and universities, and INPO. The United States also benefits from a strong, independent regulator to enforce standards—standards as crucial to public safety as the technology design itself.

Through its leadership, the United States can do much to encourage and transfer the safety culture, standards, and infrastructure needed for safe operations. This is already happening: U.S. nuclear utilities share their experience by sending experts overseas and inviting nuclear operators from developing nations to visit and study our operations.

International institutions have a role as well. The IAEA [International Atomic Energy Agency] advances standards worldwide and helps countries exploring commercial nuclear power to properly evaluate the many technical and institutional issues essential to safe, reliable operations. WANO [World Association of Nuclear Operators] is becoming a strong bearer of nuclear standards, driving excellence in nuclear plant operations in ways similar to those practiced by INPO. The U.S. industry has been active with both of these organizations.

Through INPO and WANO, we have had several international forums that bring together nuclear program leaders from throughout the world to share lessons learned. Largely because of these forums, we're now seeing strategies similar to the FLEX strategy being developed in other countries.

***EJ: Is a sense of urgency needed?***

**Scarola:** Urgent action is needed, but it needs to be deliberate as well. As we try to influence standards internationally, we must be mindful of cultural differences. For example, in the United States, workers are encouraged to speak up and point out when activities or direction is not conducive to safe outcomes. In some societies, this could be viewed as being

"If we do not fully understand and adopt modern communications, we risk being perceived as unwilling to share information openly."

"The most significant lesson [from Fukushima] was the value of diversity—in other words, making sure plants have many possible paths out of a challenge."

disrespectful or even insubordinate, so the methods may need to be adjusted to ensure that all workers are promoting safe operations.

**EJ:** *What collaborative R&D in the next five years can address the energy security challenge you describe?*

**Scarola:** We need to stay on the leading edge of new methodologies, new techniques, and new equipment and offer those to help developing countries implement new technologies. Passive safety systems continue to be at the forefront. We should also continue to advance intelligent, automated control systems and advanced monitoring systems. These are excellent opportunities to improve safety.

There is also a human resources challenge that needs to be addressed. Progress implementing some technologies, such as advanced digital control systems, is limited because they are understood by a small group of very knowledgeable individuals. So as we move forward with joint efforts, our collaborative skills—sharing lessons and advancements—will be very important in the implementation of these technologies. Collaboration in R&D is a gate to the future.

**EJ:** *What should EPRI emphasize?*

**Scarola:** EPRI provides a focal point to bring together domestic and international capabilities in those areas that can provide the greatest benefit—whether it's advancing the implementation of technologies, monitoring technologies, or communicating standards to guide operations. An example of this is the role EPRI played to

support the Fukushima Steering Committee and the industry in evaluating accident venting strategies. The analysis created the basis to change injection and spray strategies to reduce the potential for particulate release following an accident. These are results that matter—continuing improvement in environmental protection and public safety.

**EJ:** *How should we factor in the reach and speed of communication in a "wired world"?*

**Scarola:** The nuclear industry needs to recognize the fast pace at which information is flowing now and how communications can help us move forward. If we do not fully understand and adopt modern communications, we risk being perceived as unwilling to share information openly. For example, through video links to overseas counterparts, we can remotely monitor plants, evaluate data, and provide technical assistance and troubleshooting, with support from experts with diverse skills. This allows us to see dynamic information in real time that in the past may have had to be transcribed and transmitted in static forms.

**EJ:** *With these points in mind, how do you see nuclear power changing over the next five to ten years?*

**Scarola:** This is a very important time for the nuclear industry. Our first generation of plants is moving into life extensions, many beyond 40 years and some considering life beyond 60 years. This is already happening in the United States, and there will be challenges related to upgrading technology to ensure safe operation over

extended periods. New plants are under construction with new passive technologies. Plants where construction stopped years ago are restarting. It will be important to advance the technology with the new plants, many of which will be outside the United States. The lessons that we learn in those new plants will benefit the entire fleet and the next generation of plants.

**EJ:** *How should regulatory paradigms and approaches change to align with new plant technologies?*

**Scarola:** The risk profiles of new plants differ from those of older plants. New plants will have passive systems with improved risk profiles. The new technology should provide a platform for the industry to enhance oversight, improve regulatory processes, and optimize emergency planning and security for the new facilities. Maintaining the same regulatory burdens for new technologies that we required for older technologies may impact the cost-effectiveness of the new technologies and discourage their implementation. Discussions between industry and regulators on how to change the regulatory framework are already happening. It's important to be very candid in those discussions about what is appropriate to achieve public safety with the right margins—that is, using designs that can withstand conditions beyond those normally expected and still operate safely.

**EJ:** *What actions are planned next by the Fukushima Response Steering Committee?*

**Scarola:** While the committee's main focus is continuing implementation of the FLEX strategy at all plants, it is also working with regulators to define appropriate methods to re-analyze natural hazards such as seismic events and flooding. This work must be guided by sound engineering and reasonable assumptions.

**EPRI Demonstrates Alloy That Could Reduce Plant Workers’ Cobalt Radiation Exposure by up to 20%**

Culminating almost 30 years of materials research, EPRI has demonstrated in the laboratory a new alloy for hardfacing select nuclear plant components to improve their resistance to wear and *galling*, a form of damage in which material is extracted from the component’s surface. Use of this alloy, called NitroMaxx, will also help reduce worker radiation exposure. EPRI is seeking to patent NitroMaxx and in 2015 will continue to characterize its properties through laboratory and field testing.

**A Tale of Three Hardfacing Alloys: Stellite, NOREM, and NitroMaxx**

Power plant components are typically made by forging or casting metals and then applying surface treatments called *hardfacings* to provide resistance to wear and galling. In nuclear plants, cobalt-based hardfacing alloys, such as Stellite, have been used for many years because of their weldability and wear resistance. But breakdown of such materials releases elemental cobalt, which is transported through coolant flow streams into the fuel core where it is irradiated and converted to radioactive cobalt-60. This circulates back to other parts of the plant, resulting in a major source of worker radiation exposure.

Stainless steel-based hardfacing alloys have the potential to reduce cobalt-related radiation in nuclear plants by 15–20%. In the 1980s, EPRI developed such a material, called NOREM. But this and similar alloys are difficult to apply through welding and are susceptible to significant galling at temperatures above 200°C. When galling develops on the surface of a valve seat, for example, the valve may seize—potentially leading to plant safety risks. Since the 1980s, the nuclear industry has evaluated more than two dozen cobalt-free hardfacing alloys, but none has demonstrated adequate wear and galling resistance—until EPRI’s stainless steel-based NitroMaxx.

NitroMaxx grew out of four years of research and development to characterize the structural properties and degradation mechanisms of existing cobalt- and stainless steel-based alloys. In particular, EPRI researchers gained a better understanding of how galling develops. Through this work, the team figured out how to create a durable alloy that could effectively resist galling and wear.

To design NitroMaxx, researchers super-saturated the matrix of a stainless steel alloy with nitrogen—an approach that has long been known to increase hardness. One key to NitroMaxx’s galling resistance is its high *strain-hardening rate*—a property that allows

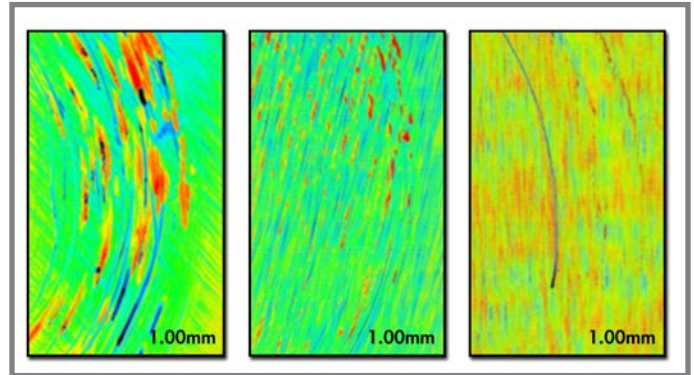

*Laser micrographs of NOREM (left), Stellite (center), and NitroMaxx (right) samples subjected to the same stresses at plant operating temperature reveal almost no galling (indicated by the thick streaks) for NitroMaxx and significant galling on NOREM.*

the alloy to become harder at the surface when subjected to strain.

The manufacture of NitroMaxx is made possible through the use of powder metallurgy and hot isostatic pressing, which involve heating and consolidating metal powders. With powder metallurgy, manufacturers can optimize an alloy’s composition and structure with great precision, allowing the application of hardfacing alloys to components without welding.

NitroMaxx has potential application on many nuclear plant components, including valves, gates, and certain reactor pressure vessel internals.

**From the Laboratory to the Field**

In laboratory tests, EPRI researchers subjected samples of NitroMaxx, Stellite, NOREM, and other alloys to various sliding wear and galling tests at a typical nuclear plant operating temperature (343°C). Using a laser microscope to examine the resulting degradation, they determined that NitroMaxx’s resistance to galling and wear was much greater than NOREM’s and similar to Stellite’s (see images above).

In 2015, EPRI is performing additional tests in simulated nuclear plant environments to gauge NitroMaxx’s durability, corrosion resistance, and performance during temperature and pressure cycles. The next step is to work with utilities and manufacturers to field-test components in noncritical plant applications.

*For more information, contact David Gandy, [davgandy@epri.com](mailto:davgandy@epri.com), 704.595.2695.*

## EPRI Completes Testing of New Cyber Security Protocol

Cyber security in the electric power sector has emerged as a priority in the national political agenda. President Obama, who repeatedly emphasizes grid security as a national security issue, recently signed an executive order urging companies to share information about cyber threats with one another and with the government.

EPRI has taken steps to reduce exposure to cyber threats by testing new security features for the North American utility industry's most widely used communications protocol: the Distributed Network Protocol (DNP3).

DNP3 was developed in the early 1990s, when devices that manage the grid were not connected to the Internet and required no cyber security measures. With the advancement of the smart grid, an industry collaborative known as the DNP Users Group developed DNP3 Secure Authentication version 5 (DNP3 SA5) to provide secure communication among computers, field devices, and systems in control centers and substations. The National Institute of Standards and Technology has recognized DNP3 as a key standard in smart grid deployments.

The DNP3 SA5 security features tested by EPRI focus on threats to the authenticity and integrity of data being exchanged. They ensure that exchanges arise from a trusted source and have not been subject to tampering and "eavesdropping." According to Ralph King, EPRI principal technical leader for cyber security, utility asset operators want vendors to supply this level of security, and vendors want to supply it.

### Mission Accomplished

In September 2014, technical experts and vendors gathered at EPRI's Cyber Security Research Lab in Knoxville, Tennessee, to demonstrate interoperability among products running DNP3 SA5. Companies represented included Applied Systems Engineering, Eaton, ESCRYPT, GRIDCO, OSI, NovaTech, Schneider Electric, Subnet, and Triangle Microworks.

Over the three-day "DNP3 Plug-Fest," EPRI led participants through almost 200 test scenarios to demonstrate the communication protocol's basic functions, showing that its different versions can coexist and serve all components in a typical utility deployment.

Eaton's Jacques Benoit told EPRI that the DNP3 SA5 is "a key element in industry's answer to the growing concern about the security of the electrical sector."



*Technology vendors gathered at EPRI's DNP3 Plug-Fest to test new security features for the utility industry's most widely used communications protocol.*

### DNP3 Security Implementation

Following Plug-Fest, EPRI hosted a technology transfer workshop for utilities and vendors and published a DNP3 SA5 implementation guide and demonstration report.

For utilities wanting to implement DNP3 SA5, King recommends starting with an inventory of devices, determining their security requirements, and working with vendors to ensure that the protocol is supported. Some devices may currently support the protocol while others may require an upgrade from the vendor. King also advises preparing and executing a comprehensive test plan before implementation.

"You should also consider phasing in the implementation," said King. "You want to be methodical about it."

*For more information, contact Ralph King, [reking@epri.com](mailto:reking@epri.com), 865.218.8160.*

## A Promising New Way to Reduce Radiation Exposure to Nuclear Workers: Computerizing Verification Tasks

EPRI is developing a prototype system using tablet computers equipped with camera or video connected to databases to verify the open-or-closed status of a valve or switch in a nuclear power plant. Testing began last June at the Tennessee Valley Authority's Bellefonte Nuclear Generating Station, and a second testing phase is in progress. If successful, the device will perform vital verification tasks now done by humans—saving time, reducing human error and radiation dose, and improving plant reliability.

### Independent Verification in the Hands of Machines

Since the dawn of the nuclear power industry, plant workers have been tasked with double-checking the work of their colleagues. In a typical scenario, when a worker opens or closes a valve, an independent verifier follows and rechecks everything, ensuring that the first worker didn't make any mistakes. With roots in the U.S. nuclear navy, such independent verification has long been a core tenet of the industry's safety culture.

There are potential downsides to human verification. Every check pulls a worker away from another job, with possible radiation exposure. People are prone to attention lapses, particularly during repetitive verification tasks, and may be reluctant to question a trusted colleague's work.

But what if a handheld tablet computer could do the work of a human verifier? To investigate this question, EPRI developed a prototype. Here's how it works. The user performs a procedure—such as closing a valve—and at each step photographs the component with the tablet's digital camera. The tablet's software compares each photograph with a laser-scanned three-dimensional model of the component, recording and detecting whether the component is open or closed. As the software determines that a given step in the procedure is completed, it allows the user to move to the next step.

Embedded in the procedure is a fully independent verification that both avoids the need to dispatch a second person later and catches rare-but-inevitable human errors for better reliability. Because the procedure is driven by tablet software, no paperwork is required.

At the Bellefonte station, researchers tested procedures on gate valves, butterfly valves, lighting panel switches, and motor control center breakers. In each procedure, the prototype accurately verified the component's status.



*A plant technician uses the tablet technology to verify the completion of a valve alignment.*

### Refining the Verifier

EPRI is conducting a second test phase at Duke Energy's Catawba Nuclear Station in 2015 to investigate the use of video. The verifier moves the tablet's video camera 360 degrees around a component and processes the video into a three-dimensional representation of the component. The software compares this image with the reference model to determine the component's open or closed status.

Also, researchers plan to make the system fully portable and self-contained, eliminating the need to be docked to a separate laptop to run the verification software. They want to investigate the economic feasibility of building a digital library of three-dimensional reference shapes of thousands of plant components potentially requiring verification.

If a workable device is commercialized, human verifiers will be among the key beneficiaries. "We respect radiation," said David Ziebell, EPRI senior technical leader. "If we send somebody out to containment to do a valve alignment, that person's going to absorb dose. If we send a second person out to verify, that person's also going to absorb dose. If we can reduce that, that's a win for all involved."

*For more information, contact David Ziebell, [dziebell@epri.com](mailto:dziebell@epri.com), 404.316.9823.*



## EPRI Software Platform Gives Plug-In Electric Vehicles a Charge

Since automakers first began rolling out plug-in electric vehicles (PEVs) in the United States in December 2010, approximately 300,000 have hit the streets and the grid. Market researchers estimate that the fleet could surge to 3 million in the decade ahead.

By the mid-2020s, PEVs will be in their teens as commercial products, and as is typical of teens, they may be unpredictable and potentially disruptive. Millions of independently operated electric vehicles intermittently charging their batteries could place additional stress on the grid—especially during peak electricity demand in areas with concentrations of PEVs. Minimizing grid impacts could be achieved by coordinating the fleet to charge off-peak, but this requires better communication between electric vehicles and grid operators than exists today.

To address these challenges and opportunities, EPRI worked with Sumitomo Electric Industries, eight automakers, and a dozen utilities over the past two years through the Open Vehicle-Grid Integration project to develop a software platform to manage grid-connected electric vehicles as integrated resources.

The open-standards, central-server platform enables a single, universal communication interface with PEVs through all available utility smart grid and public broadband channels, as well as vehicle telematics systems. This enables utilities to send requests to vehicles to manage charging in ways that help balance electricity supply and demand while allowing for customer preferences related to mobility and charging. Until now, managing grid-to-PEV communications has been made cumbersome by carmakers using diverse protocols.

### The Big Demo

Last October at the Sacramento Municipal Utility District (SMUD), EPRI hosted an event called the Big Demo to showcase the software platform for officials from the California Energy Commission, California Public Utilities Commission, California Independent System Operator, utilities, automakers, and other stakeholders in the emerging smart-charging market.

“There was a lot of nervousness,” recalled Sunil Chhaya, manager of EPRI’s Open Vehicle-Grid Integration Program. “But with all the choreography that went into it, everything went off without a hitch.”

Seven electric vehicles from different manufacturers were plugged into charging stations in SMUD’s parking lot, and all responded simultaneously to the same demand response signal from the platform—the first such demonstration ever.



*Plug-in electric vehicles from different manufacturers charging in SMUD’s parking lot as part of EPRI’s Open Vehicle-Grid Integration Platform demonstration*

“The purpose of the Big Demo was to demonstrate the superior application of the platform approach to managing diversity among end-users,” explained Chhaya. “We wanted to show what this technology could do—and a better way to collaborate on its development.”

### The Next Steps

In 2015, the project’s second phase focuses on the platform’s reliability, security, and scalability. EPRI will develop a prototype with more management and communications capabilities and launch large-scale demonstrations with utilities in areas with high PEV sales. In the third phase, in 2016, EPRI will begin to incorporate ancillary services such as frequency regulation and operating reserves—as well as voltage control and balancing intermittent renewable power generation.

“This is where we enable commercialization of this technology,” said Chhaya.

If successful, the program could save ratepayers money by reducing utility costs for charging load management and grid infrastructure upgrades, while enabling integration of more renewable generation and allowing utilities to tap the full potential of PEVs.

EPRI will explore ways to extend the platform to other distributed energy resources, including solar, batteries, and end-use devices such as air conditioners and pool pumps. “These devices are smart to an extent, but there is no communication or coordination among them,” said Chhaya. “The software platform could help utilities to harness them as grid assets.”

*For more information, contact Sunil Chhaya, [schhaya@epri.com](mailto:schhaya@epri.com), 650.855.2148.*

## In First-of-Its-Kind Test, EPRI Demonstrates Open-Phase Detection System for Nuclear Plant Transformers

Based on laboratory tests, EPRI team leaders Wayne Johnson and Bob Arritt were confident in a new technology to detect and alert nuclear plant operators to unstable conditions on a transformer. The Tennessee Valley Authority (TVA) collaborated with EPRI in bringing an engineering team to the Bellefonte Nuclear Station last May to test EPRI's Open-Phase Detection System as TVA initiated an open-phase fault on a large transformer connecting the plant to TVA's grid.

A test of this type had never been attempted. With leaders from the U.S. Nuclear Regulatory Commission (NRC), Institute of Nuclear Power Operations, Southern Nuclear, and several engineering firms looking on, the technology's moment of truth came when operators broke the path of one conductor on the power lines that feed the transformer to determine whether the system could detect the open phase.

Open-phase conditions—if left undetected for a long time—can cause damage to nuclear plant equipment, such as overheated motors, and loss of power to the plant. Although researchers were familiar with several open-phase events in the field lasting for weeks, the test's risks were real.

"We had to clear the switchyard as a standard safety precaution. People were inside buildings a considerable distance away from the transformer," Arritt said.

The outcome: the system successfully detected open-phase conditions, and TVA collected detailed electrical data throughout the plant for a better understanding of an open-phase fault's effects.

### Open Phase: What's the Big Deal?

Open-phase conditions can result from failed connections or disconnect devices in the transmission system. Traditional open-phase detection methods measure changes in voltage and current. But because some transformer configurations don't normally exhibit changes in voltage, these methods may not detect all events.

Detection systems typically—but not always—perform in fractions of a second. In 2012, it took operators at Exelon's Byron Nuclear Station eight minutes to detect an open-phase event caused by a switchyard component failure.

"Eight minutes electrically can be an eternity," Johnson said.

The event resulted in a loss of grid power supply to the plant, drawing industry attention to the potential consequences of detection failure. Since 2001, the NRC has reported 11 other



Wayne Johnson (left) and Bob Arritt (right) stand by EPRI's Open-Phase Detection System at its successful demonstration at TVA's Bellefonte Nuclear Station.

open-phase events that went unnoticed for extended periods. The NRC also reports that several international plants have experienced events.

### Affordable Solution from EPRI

For more comprehensive open-phase detection, EPRI's system monitors changes in system *impedance*—a measure of how current flows through a conductor. It does so by connecting two monitoring devices to a transformer's *neutral line*—the wire that connects the transformer's windings to ground. One device listens for an open-phase condition on the grid side of the transformer; another manipulates electrical conditions as it listens for an open phase.

The system can operate on any power supply and detect open phases under all loading conditions. Its commercial, off-the-shelf parts reduce cost and simplify maintenance.

Installation and integration are easy, requiring only routing the transformer's neutral connection through the system and back to ground.

"This is the first time a test like this was ever attempted in the world, and it was done in the name of science and nuclear safety," said Mark Bowman, TVA senior program manager for electrical systems analysis.

The successful test at Bellefonte has enabled commercialization of the Open-Phase Detection System. Power System Sentinel Technologies supports installation and commissioning of the commercial version.

For more information, contact Wayne Johnson, [wejohnson@epri.com](mailto:wejohnson@epri.com), 704.595.2551, or Bob Arritt, [barritt@epri.com](mailto:barritt@epri.com), 864.218.8067.

## Flexible Probe Lends Hand to Crack Detection in Heat Recovery Steam Generators

During a meeting with a colleague from Southwest Research Institute (SwRI) in 2011, EPRI's Stan Walker was trying to imagine the perfect tool for detecting cracks in the most vulnerable, hardest-to-reach nooks and crannies at power plants.

In heat recovery steam generators at combined-cycle–natural-gas plants, for instance, joints where steel tubes are welded to cylindrical headers have proven especially challenging to search for surface defects using conventional means. Many other power plant components and weld orientations with various surface geometries make it difficult to design a suitable inspection fixture.

Walker recalled how he and his colleague arrived at a solution: “I said, ‘If we could just make a tool that moves like my finger, able to move around a weld joint and maintain contact the whole time.’ And he added, ‘Now, if we can just make a flexible probe and put it on the end of your finger or glove.’”

### A Magic Glove

From this brainstorm, SwRI and EPRI developed the flexible eddy current probe, which attaches to the finger of a glove and is designed specifically—and literally—for manual screening. The probe is based on printed circuit board technology using spiral metal coils embedded in a flexible substrate. The coils identify cracks using magnetic current fields.

“The probe is like a thick piece of scotch tape, not hard,” explained Walker. “At a power plant, you normally use gloves anyway, so we first placed the probe on a glove finger.”

The examiner places the finger-mounted probe on an area to be inspected, and finger pressure conforms it to the surface geometry. For example, the operator can bend his finger to inspect the circumference of a weld joint. The flexible probe connects via a small, rigid printed circuit board interface in the glove's palm to a portable instrument that connects to a computer for viewing test results.

Typical eddy current probes are rigid, handheld devices shaped like a pencil or rectangular box. They are widely used to find defects in flat metal surfaces at power plants and in the aerospace, automotive, and chemical industries. But for weld joints and other complex geometries, such devices are often inadequate. Examinations are sometimes conducted with liquid penetrant, which can be messy in tight spaces.



*A glove equipped with the flexible eddy current array probe is used to inspect tube-to-header welds in a heat recovery steam generator.*

### Crack Detection in Field Demonstrations

Last year in field tests on heat recovery steam generators at four combined-cycle–natural-gas power plants, EPRI and SwRI demonstrated how the glove probe literally lends a hand in crack detection.

“In an examination at Southern Company's Rowan Plant in North Carolina, we found three cracks plant staff had already discovered and one additional crack they didn't see,” said Walker. “They wanted to know about other applications, so we demonstrated it on combustion turbine buckets, compressor blades, and the turbine rotor.”

Based on the field tests, improvements have been made ahead of the probe's planned 2015 commercial launch. The flexible probe and printed circuit board, originally placed in a pocket sewn into the glove, are now attached with Velcro. The commercial product—which SwRI has been licensed to sell—will include all components for portable use, including a rugged tablet computer.

In addition to the glove probe, SwRI is working under contract with EPRI to interface the flexible probe with other small, portable instruments. The two companies also are evaluating designs for a robotic probe with two extendable arms to examine areas where fingers cannot reach. Called the Mechanized Over/Under Slung ET, or MOUSE, this version will travel on magnetic, motor-driven wheels along the underside of headers.

“It's a low-cost tool, and we are still finding all these new things we can do with it,” said Walker.

*For more information, contact Stan Walker, [swalker@epri.com](mailto:swalker@epri.com), 704.595.2581.*



## Member applications of EPRI science and technology

### EPRI Software Validates Power Plant Simulation Models, Cuts Utility Operating Costs

Before joining EPRI, Pouyan Pourbeik worked among a select group of industry specialists who develop models to simulate how power plants respond to various conditions and conduct field tests to validate these models. Pourbeik and his peers became sought after as regional interconnection authorities started requiring plant operators to perform model validation for their natural gas- and steam-powered generators. Their skills became a key part of utility planning and operations.

With plant operators paying consultants \$15,000 to \$30,000 for each generating unit model validation, Pourbeik joined EPRI in 2006 to develop software that reduces engineering time and enables plant operators to validate model results in-house.

Since its release in 2007, demand has continued to grow for EPRI's software, known as the Power Plant Parameter Derivation tool. Standards approved last year by the North American Electric Reliability Corporation (NERC) require the entire North American generation fleet to conduct model validation every 10 years.

"Now that everybody has to do this, it may not be practical to rely on consultants alone," said Pourbeik. "Every consultant would be traveling almost all the time."

#### On-Line Testing Reduces Downtime

Model validation typically requires operators to conduct several time-intensive tests, which may include disconnecting load-carrying generators from the grid and exposing the turbine-generator shaft to stress resulting from the sudden load removal. Using EPRI's model validation software, operators do not need to remove generating units from service for testing. The software collects online data on the power plant's electrical variables during disturbances that affect plant equipment. It then processes the data to characterize the response of the generator and controls, uses the response characteristics to estimate power plant model parameters, and compares these parameters with the online data. With this analysis, the software helps operators to update parameters in plant models and identify potential problems with control system settings and operation.

For large generating units such as those at Tri-State Generation and Transmission Association's Craig Station facility in Colorado, the software helps avoid 4 to 6 hours of downtime for each model validation.

Tri-State is one of 23 utilities, independent power producers, and independent system operators that support the EPRI software as a users' group. Pourbeik, who conducts annual training sessions



Duke Energy used EPRI's software to complete model validation for its McGuire Nuclear Station.

on the software, estimates that power plant owners have used it to validate approximately 100 generating units.

#### Technology Transfer: Simple and Inexpensive

Many power plant operators already have the equipment needed to implement EPRI's software. For decades, they have used digital fault recorders to capture and record electrical signals associated with grid disturbances. For model validation, they simply need to set up the device to record additional online plant data. Because NERC is developing standards requiring more power plants to use fault recorders, implementation will become more straightforward and less expensive. According to Pourbeik, plant operators can justify the one-time expense of fault recorders without a mandate.

Prior to joining the users' group, Randy Rhinier, a Duke Energy expert in systems that control voltage at power plant terminals, had little background in model validation. With Pourbeik's support, he was able to start implementing the software in a couple of weeks. Now he can complete model validation and issue a report in less than 30 hours. "I continue to learn through the annual meetings and other users' experiences," said Rhinier.

The software has helped Duke to comply with NERC validation standards at its generating units in North Carolina and South Carolina. Rhinier is turning his attention to about 100 power generating units requiring validation in Duke's Florida and Midwest territories, expecting to handle 80–90% of them in-house with the EPRI software.

According to Rhinier, the software will save Duke \$12,000 to \$20,000 in consultant costs per generating unit.

For more information, contact Pouyan Pourbeik, [ppourbeik@epri.com](mailto:ppourbeik@epri.com), 972.556.6577.



## MISO Taps EPRI Software to Envision the Future

Five years ago, John Lawhorn and his staff at the Midwest Independent System Operator (MISO) faced a challenging question: How would the U.S. Environmental Protection Agency's (EPA) proposed Mercury and Air Toxics Standards impact electric companies and other stakeholders in the 11 states where MISO was responsible for delivering reliable, cost-effective power? (The grid operator MISO has since expanded to 15 states and is now called the Midcontinent Independent System Operator.) Their prediction that the rules would lead to the retirement of about 12,000 megawatts of coal-fired generation capacity was remarkably accurate. To date, about 10,000 megawatts have been retired.

Lawhorn isn't psychic. Rather, he relied on the EPRI software Electric Generation Expansion Analysis System, or EGEAS, which has become essential for his policy and economic analysis work at MISO. "We run it every day and have trained 15 people to use it since first obtaining it seven years ago," said Lawhorn, who received a 2014 EPRI Technology Transfer Award.

Electric system planners like EGEAS because it can analyze many complex, multi-year resource planning scenarios in just minutes—much faster than similar software.

EPRI first developed EGEAS in the early 1980s and has continually enhanced it with new features. Later this year EPRI will release version 11, funded in part by MISO. EPRI licenses third-party software firms to provide training and support for EGEAS users.

### A Key Tool for Transmission Planning

EGEAS analysis is step one in MISO's annual seven-step planning process to ensure system reliability and compliance with state and federal requirements. MISO and its stakeholders typically identify four scenarios to reflect evolving policies by analyzing load forecasts, fuel prices, demand response, energy efficiency, renewable energy penetration, and other variables. They run the scenarios through EGEAS and use the results to support generation capacity planning, power plant siting, and assessing costs and power flows in the system.

For example, to help determine new power plants needed to meet electricity demand in five years, EGEAS can project future load, cost and performance of various generation technologies, and cost of environmental regulatory compliance—and then provide guidance on the most economically efficient power plant construction.

Without EGEAS, long-term generation planning would



require MISO to gather information that electric companies would rather not supply. "Due to business confidentiality, the generators typically will not disclose their generation plans," said Lawhorn. "EGEAS allows MISO to set the needed generation forecast without that information."

With respect to state and federal policies, MISO uses EGEAS to analyze cost implications for stakeholders such as electric companies, regulators, independent power producers, and power marketers. A recent assessment of the potential impact of the EPA's Clean Power Plan, which seeks to limit carbon dioxide emissions from existing power plants, indicated the possible retirement of another 14,000 megawatts of coal plants.

Because of the tool's demonstrated value, MISO has suggested that regulators and electric companies in its territory use it for their own analyses. Doing so, said Lawhorn, will make communication easier. "When you start talking regulations, it's helpful if everyone speaks the same language," he said. Of the 15 state public utility commissions in MISO's territory, 10 currently use EGEAS.

### Users Around the World

Electric companies and regulators in Egypt, Israel, Malaysia, Saudi Arabia, Taiwan, and Thailand have used EGEAS for analyses, and one Asian company used EGEAS to plan power plant construction to best support regional economic development.

While MISO has devoted substantial resources to train its personnel to use EGEAS, such investment is not always required for significant benefits. "We know of a small utility where one person is responsible for generation planning," said Adam Diamant, a technical executive in EPRI's Energy and Environmental Analysis Program. "And he has become a powerful EGEAS user, too."

*Free EGEAS resources are available [here](#). For more information, contact Adam Diamant, [adiamant@epri.com](mailto:adiamant@epri.com), 510.260.9105.*



Key deliverables now available

*The following is a small selection of items recently published by EPRI. To view complete lists of your company-funded research reports, updates, software, training announcements, and other program deliverables, log in at [www.epri.com](http://www.epri.com) and go to Program Cockpits.*

## [Guidance for Developing a Human Factors Engineering Program for an Operating Nuclear Power Plant \(3002002770\)](#)

Human factors engineering—which applies knowledge of human mental and physical capabilities to the design of devices, systems, and tasks—has become more important as operating nuclear plants modernize. This report provides guidance on developing human factors engineering programs for plant modifications.

## [Advanced Light Water Reactors Utility Requirements Document: Small Modular Reactors Inclusion Summary \(3002003130\)](#)

Growing interest in small modular nuclear reactors has prompted more detailed technical analysis by utilities, regulators, researchers, and other stakeholders. This report summarizes modular reactor-specific changes to EPRI's utility requirements document, a routinely updated report outlining owner/operator requirements for new nuclear plants. A brief overview of the changes is available [here](#).

## [Automated Distribution Automation Switch Placement \(3002003238\)](#)

Utilities spend millions of dollars per year deploying automated switching devices on distribution feeders. While analysis has shown that reliability improvements from these devices depend on their location, decisions on where to place them are often based primarily on experience and gut instinct. This report details a new algorithm that can automate the process of determining optimal locations and potentially yield millions of dollars in additional reliability benefits for utilities.

## [Mobile Technology Guidebook \(3002004206\)](#)

This report surveys emerging mobile technologies for utility applications, such as augmented reality and access to data and expertise in the field. It describes each technology's status, problems it can address, expected evolution, and potential industry impacts and pitfalls.

## [Demonstration Development Project: PMscreen Pilot-Scale Evaluation \(3002004292\)](#)

This study evaluated the performance of a 1-megawatt pilot-scale version of an EPRI-patented particulate matter screen at a lignite coal-fired power plant site, confirming the technology's potential as a suitable retrofit for supplementing particulate matter removal.

## [Cyber Security Tabletop Exercise Facilitation Plan and Master Scenario Event List \(3002004722\)](#)

With increasing deployment of automated equipment and interconnection of systems and devices in the electric sector (including IT and telecommunications equipment), tabletop exercises that assess utilities' preparedness for cyber security events have become more important. In addition, many utilities have regulatory requirements to perform cyber security exercises. This report provides procedures and example scenarios that utilities can use to run their cyber security tabletop exercises.

## [Bolted Gasketed Joint Maintenance Application Version 1.0 \(3002004813, 3002003224\)](#)

Developed with video gaming technology, this interactive application demonstrates maintenance procedures for bolted gasketed joints in nuclear plants. EPRI is collecting input on this beta version from utilities and industry experts. Includes versions for [Android](#) and [Windows](#).

## [Long-Term Emissions and Air Quality Trends in the United States \(3002005240\)](#)

This report documents the results of an analysis of emissions and air quality trends in the contiguous United States from 1970 to 2011. The analysis is part of a larger EPRI study to quantify emissions contributions to ozone and particulate matter from various geographical sources and sectors.

## [Assessing Ecosystem Services Using the InVEST Model: Case Study of the American Electric Power ReCreation Lands, Ohio \(3002005275\)](#)

This study used the Natural Capital Project's InVEST model to assess impacts of various land uses on ecosystem services in American Electric Power's ReCreation Land, a 60,000-acre reclamation project in Ohio. It evaluated several scenarios involving the installation of shale gas well pads and construction of service roads.



Lisa Edgar  
*President, National Association  
of Regulatory Utility Commissioners*

## The Integrated Grid: A Timely, Essential Conversation to Help Regulators Navigate an Industry Transformation

In 15 years, we may not recognize much about utility regulation as it is today. Innovative technologies that could revolutionize how we use and consume electricity are already in play. Because much of this modernization is taking place at the distribution level, state commissioners have taken a keen interest in EPRI's Integrated Grid research on tools to realize the full value of a transformed grid.

At the last two winter meetings of the National Association of Regulatory Utility Commissioners (NARUC), EPRI officials presented their latest reports. Importantly, the Integrated Grid concept embraces the diversity of our nation's electricity industry. As state regulators are fond of saying, there is no one-size-fits-all solution to utility planning. Any efforts to modernize the system must take this into account.

The concept fits nicely with my theme as NARUC President—Coast to Coast: Consumers, Convergence, Change. As various states and regions address the many challenges ahead, different solutions and trends will emerge. At its core, though, the Integrated Grid must maintain and improve reliability and provide ample benefits for the customers served and costs incurred.

As utility regulators, our job is to help bring some certainty into this rapidly changing industry—to ensure safety, reliability, customer affordability, environmental sustainability, and financial viability. This applies to all customer types, from residential to large industrial, traditional utilities, and newly emerging technologies and enterprises.

Our unique reality is that we have to regulate in the public interest while our systems are in transformation. We must consider—and even encourage—the changes that are here and those that are coming. We must add value without adding undue risk.

And that's hard. But I know, coast to coast, we are up to the challenges. We must be adaptive in our processes, recognize and appreciate our regional differences, share ideas, and stay true to our state issues and mandates. This is why so many NARUC members are intrigued by EPRI's Integrated Grid project.

As the saying goes, "Timing is everything," and the EPRI Integrated Grid research could not be more timely. States across the country are asking questions about distributed generation and its potential impacts on the grid, consumers, and the utility business. Utilities continue to roll out smart meters to provide consumers with more control over their energy use. At the same time, interest in solar has surged, and many utilities are testing the impacts of widespread integration into the grid. Also, studies on micro grids,

energy storage, and electric vehicles are ongoing—potentially resulting in new demands on the electricity system.

Clearly change is upon us, and regulators are eager to see the results of this ambitious EPRI program. It is important that these technologies, as promising as they appear, be utilized in a manner that both protects consumers from unexpected rate increases and improves service. In these days of social media and instant communication, consumers have more information about their electric service than ever before. Many want information and choices, and it is the regulator's job to make sure that consumers of all types benefit from these changes.

It is also incumbent upon EPRI and the utility industry to communicate with consumers throughout this project. We must all reach out and explain the benefits and costs associated with the changes we see. Consumers expect and deserve a two-way conversation.

State regulators are excited about the future. There is no better time to be involved in this sector than right now. The decisions we make over the next few years will have lasting implications. Let's use this opportunity to work together and focus on making the Integrated Grid work for all.

1300 West W. T. Harris Blvd.  
Charlotte, North Carolina 28262

**ADDRESS SERVICE REQUESTED**

NONPROFIT ORGANIZATION  
U.S. POSTAGE  
**PAID**  
SALEM OR  
PERMIT NUMBER 526

---

# JOURNAL

EPRI

ELECTRIC POWER RESEARCH INSTITUTE

SPRING 2015